



CHAMPION AEROSPACE LLC

AVIATION CATALOG
AV-14

REVISED AUGUST 2014

Spark Plugs
Oil Filters
Slick by Champion
Exciters
Leads
Igniters



Table of Contents

SECTION	PAGE
Spark Plugs	1
Product Features	1
Spark Plug Type Designation System	2
Spark Plug Types and Specifications	3
Spark Plug by Popular Aircraft and Engines	4-12
Spark Plug Application by Engine Manufacturer	13-16
Other U. S. Aircraft and Piston Engines	17-18
U. S. Helicopter and Piston Engines	18-19
International Aircraft Using U. S. Piston Engines.....	19-22
Slick by Champion	23
Oil Filters	29
Product Features	29
Full-Flow Spin-On Filters	30
Typical Spin-On Filters	31
Aircraft and Engine Applications.....	32-34
Dimensional Data.....	34
Turbine Exciters	35
Product Features	35
Aircraft Engine Applications	36
Turbine Ignition Leads	37
Product Features	37
Aircraft Engine Applications	38-41
Turbine Engine Applications (APU)	41-42
Turbine Igniters	43
Product Features	43
Design Features	43
Basic Igniter Types	44
Aircraft Engine Applications	45-48
Turbine Engine Applications (APU)	48-50
Turbine Engine Applications (GPU).....	50
Service Tools & Equipment	51
Index	51
Special Tools and Equipment	52-56
Current/Discontinued Aviation Spark Plugs	56
Champion Aerospace LLC Products Warranty	57

Product Design

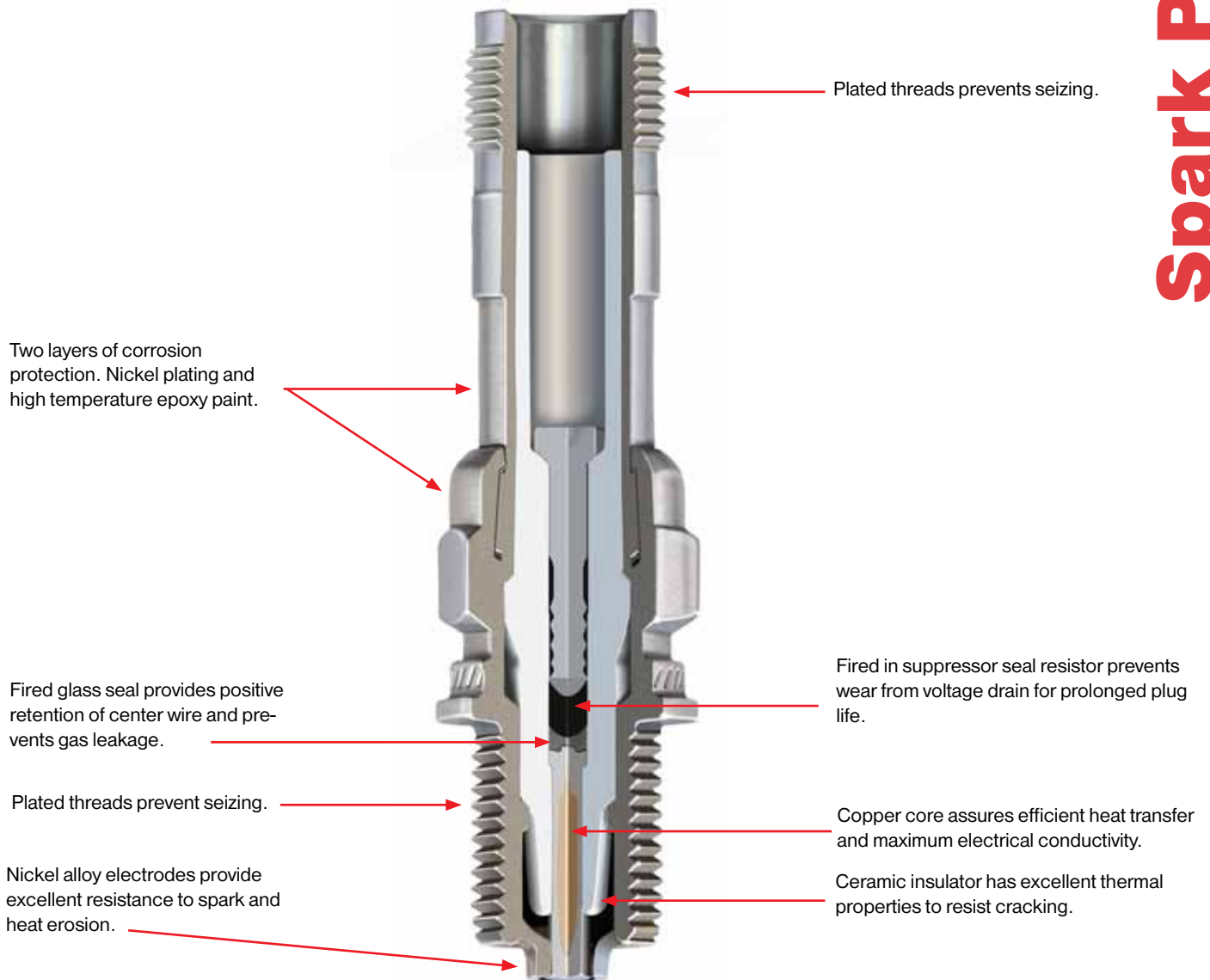

Spark Plugs

Advanced-engineered Champion Aerospace spark plugs are designed for the critical difference in performance, far beyond the ordinary. Champion Aerospace spark plugs stand up to high temperatures, pressures, and lead deposits, with a performance second to none. When you're up in the air, count on quality Champion spark plugs.

The #1 Choice Worldwide - OEM for all U. S. Piston Engines.

Champion spark plugs are a product of Champion's commitment to quality and advanced technology, a commitment that has made Champion spark plugs the #1 choice of engine manufacturers, maintenance technicians and pilots around the world.

Choose Iridium "S" spark plugs for high-performance engines.

Longer-lasting than platinum spark plugs, Iridium "S" plugs resist lead attack and provide better scavenging than standard platinum plug designs. For exceptional performance, even under the most demanding conditions.





Spark Plugs

Spark Plug Type Designation System

All Champion Aerospace spark plugs are identified by type designations as indicated on the following spark plug number and symbol chart. The symbol is composed of a rating position number, together with prefix and suffix numbers to indicate major plug design characteristics.

Typical Spark Plug Number with Symbol Explanation

R H B 37 E

Resistor

- None** - No Resistor
- R** - Mil-Spec. Resistor Erosion Protection

Electrode Design

- None** - Conventional Single
- E** - Two Electrode Massive
- N** - Four Electrode Massive
- S** - Single Electrode (Iridium)
- B** - Twin Electrodes(Nickel)
- R** - Push-wire - 90° to Center
- Y** - Projected Core Nose
- P** - Two Electrode (Platinum)
- W** - Two Electrode (Iridium)

Barrel Style

- None** - Unshielded
- E** - Shielded 5/8" - 24 Thread
- H** - Shielded 3/4" - 20 Thread (All-Weather Plug)
- V** - M18X1 - Metric

Heat Rating Position

- High Number** - Hot (50)
- Low Number** - Cold (26)

Mounting Thread

- B** - 18 mm
- M** - 18 mm
- J** - 14 mm
- L** - 14 mm
- U** - 18 mm
- N** - 14 mm

Reach

- 13/16" (2.06 cm)
- 1/2" (1.27 cm)
- 3/8" (.095 cm)
- 1/2" (1.27 cm)
- 1-1/8" (2.85 cm)
- 3/4" (1.90 cm)

Hex Size

- 7/8" (2.22 cm)
- 7/8" (2.22 cm)
- 13/16" (2.06 cm)
- 13/16" (2.06 cm)
- 7/8" (2.22 cm)
- 13/16" (2.06 cm)

Shielded Aviation Spark Plug

Shielded Aviation Spark Plugs are manufactured under military specification MIL-S-7886B.

Outside Gaskets

Champion

Part No.	Size
M-674	18 mm Solid Copper
N-673	14 mm Solid Copper

Military Specification

AN4027-1
AN4027-2

Spark Plugs



Types and Specifications

Plug Type	12 Pack Shipping Wt.	Thread Size	Reach	Shielding Thread	Standard Electrode	Fine Wire Electrode	Plug Gap
L34R	1 lb. - 13 oz. 822kg	14mm	1/2"/1.27cm	None	Push Wire		.018"-.023"/0.46-0.58mm
REJ38	2 lb. - 13 oz. 1.276 kg	14mm	3/8"/0.95cm	5/8" - 24	Single		.018"-.023"/0.46-0.58mm
REL37B	2 lb. - 13 oz. 1.276 kg	14mm	1/2"/1.27cm	5/8" - 24	Twin Electrode		.016"-.021"/0.41-0.53mm
REN30S	2 lbs. - 6 oz. 1.077 kg	14mm	3/4"/1.90cm	5/8" - 24	Single Fine Wire	Iridium	.016"-.021"/0.41-0.53mm
M41E	2 lbs. - 6 oz. 1.077 kg	18mm	1/2"/1.27cm	None	Two Prong		.016"-.021"/0.41-0.53mm
REM40E REM38E	3 lbs. - 4 oz. 1.474 kg	18mm	1/2"/1.27cm	5/8" - 24	Two Prong		.016"-.021"/0.41-0.53mm
REM38S	3 lbs. - 4 oz. 1.474 kg	18mm	1/2"/1.27cm	5/8" - 24	Single Fine Wire	Iridium	.016"-.021"/0.41-0.53mm
REM37BY	3 lbs. - 4 oz. 1.474 kg	18mm	1/2"/1.27cm	5/8" - 24	Twin Electrode		.016"-.021"/0.41-0.53mm
RHM40E RHM38E	3 lbs. - 5 oz. 1.503 kg	18mm	1/2"/1.27cm	3/4" - 20	Two Prong		.016"-.021"/0.41-0.53mm
RHM38S	3 lbs. - 5. oz. 1.503 kg	18mm	1/2"/1.27cm	3/4" - 20	Single Fine Wire	Iridium	.016"-.021"/0.41-0.53mm
REB37E REB32E	3 lbs. - 4 oz. 1.474 kg	18mm	13/16"/2.06cm	5/8" - 24	Two Prong		.016"-.021"/0.41-0.53mm
RHB37E RHB32E RHB29E	3 lbs. - 6 oz. 1.531 kg	18mm	13/16"/2.06cm	3/4" - 20	Two Prong		.016"-.021"/0.41-0.53mm
REB36S	3 lbs. - 4 oz. 1.474 kg	18mm	13/16"/2.06cm	5/8" - 24	Single Fine Wire	Iridium	.016"-.021"/0.41-0.53mm
RHB36S RHB32S RHB27S	3 lbs. - 6 oz. 1.531 kg	18mm	13/16"/2.06cm	3/4" - 20	Single Fine Wire	Iridium	.016"-.021"/0.41-0.53mm
RHU32S	3 lbs. - 6 oz. 1.531 kg	18mm	1-1/8"/2.85cm	3/4" - 20	Single Fine Wire	Iridium	.016"-.021"/0.41-0.53mm
RHU32E RHU27E	3 lbs. - 6 oz. 1.531 kg	18mm	1-1/8"/2.85cm	3/4" - 20	Two Prong		.016"-.021"/0.41-0.53mm
RVL38S	2 lbs. - 13 oz. 1.276kg	14 mm	1/2"/1.27cm	M18 x 1	Single Finewire	Iridium	.016"-.021"/0.41-0.53mm

PAINT CODE COLOR: All Standard Electrode - Silver All Iridium "S" Electrode - Gold



Spark Plugs

Popular Aircraft and Engines

U.S. Aircraft/Engine Specifications	Plugs Per Eng.	Massive		Fine Wire		U.S. Aircraft/Engine Specifications	Plugs Per Eng.	Massive		Fine Wire	
		Shielded						Shielded			
		3/4"-20	5/8"-24	3/4"-20	5/8"-24			3/4"-20	5/8"-24	3/4"-20	5/8"-24
AERONCA						Thrush S2R, S2D					
7BC						P&W R-1340 (600 hp)	18	RHM40E	REM37BY REM40E	RHM38S	REM38S
Cont C85-12 (85 hp)	8	RHM40E	REM40E	RHM38S	REM38S	Thrush S2R-800					
7CC						Wright R-1300 (800 hp)	14	RHB37E	REB37E	RHB36S	REB36S
Cont C90-12F (95 hp)	8	RHM40E	REM40E	RHM38S	REM38S	Schweizer AG-Cat G164					
15AC						Cont W-670 (230 hp)					
Cont C145 (145 hp)	12	RHM40E	REM40E	RHM38S	REM38S	Jacobs R755 (275 hp)	14	RHM40E	REM40E	RHM38S	REM38S
S15AC						Schweizer Super AG-Cat G164 A thru C					
Frank 6A4-165-B (165 hp)	12		REJ38			P&W R-985 (450 hp)			REM37BY		
11AC Chief						P&W R 1340 (600 hp)	18	RHM40E	REM40E	RHM38S	REM38S
Cont A-65-8 (65 hp)	8	RHM40E	REM40E			Weatherly 620					
11CC Super Chief						P&W R-985 (450 hp)	18	RHM40E	REM37BY REM40E	RHM38S	REM38S
Cont C85-12 (85 hp)	8	RHM40E	REM40E	RHM38S	REM38S	AMERICAN GENERAL AIRCRAFT CORP. AG5B					
AEROSPATIALE (Socata)						LycO O-360-A4K (180 hp)	8	RHM40E	REM37BY REM40E RHM38E	RHM38S	REM38S
TB9 Tampico						ARCTIC					
LycO O-320-D2A (160 hp)	8	RHM40E RHM38E	REM37BY REM40E REM38E	RHM38S	REM38S	Tern S1B2					
TB10 Tobago						LycO O-320-A2B (150 hp)	8	RHM40E	REM37BY	RHM38S	REM38S
LycO O-360-A1AD (180 hp)	8	RHM40E RHM38E	REM37BY REM40E REM38E	RHM38S	REM38S	BEECH					
TB20 Trinidad						D-17S			REM37BY		
LycO IO-540-C4D5D (200 hp)	12	RHM40E RHM38E	REM40E REM38E	RHM38S	REM38S	P&W R-985-AN (450 hp)	18	RHM40E	REM40E	RHM38S	REM38S
TB21 Trinidad TC						D18S, E18S, G18S, H18S, AT11					
LycO TIO-540-ABIAD (250 hp)	12	RHB37E RHB32E		RHB36S RHB32S		2/P&W R-985-AN (450 hp)	18	RHM40E	REM37BY REM40E	RHM38S	REM38S
TB30						Bonanza E33					
LycO AEIO-540-L1B5D (300 hp)	12	RHM38E	REM38E	RHM38S	REM38S	Cont IO-470-K (225 hp)	12	RHM40E	REM40E	RHM38S	REM38S
AG AIRCRAFT (Misc)						E33A, F33A, F33B, F33C					
AG Commander A-9 Sparrow						Cont IO-520-B (285 hp)	12	RHB32E		RHB36S RHB32S	
LycO O-540-B2B5 (235 hp)	12	RHM40E	REM40E	RHM38S	REM38S	Bonanza A35, B35					
Air Tractor AT-301/AT301A/AT401/AT501						Cont E-185 (185 hp)	12	RHM40E	REM40E	RHM38S	REM38S
P&W R-1340 (600 hp)	18	RHM40E RHM40E	REM40E REM37BY	RHM38S	REM38S	C35, D35, E35, F35					
Bull Thrush S2R-R1820						Cont E-185-11 (205 hp)	12	RHM40E	REM40E	RHM38S	REM38S
Wright R 1820 (1200 hp)	18	RHB37E	REB37E	RHB36S	REB36S	G35					
Eagle 220						Cont E-225-8 (225 hp)	12	RHM40E	REM40E	RHM38S	REM38S
Cont W-670 (220 hp)	14	RHM40E	REM40E	RHM38S	REM38S	H35					
Eagle 300						Cont O-470-G (240 hp)	12	RHM38E	REM38E	RHM38S	REM38S
LycO IO-540-M1B5D (300 hp)	18	RHB32E RHB37E	REB32E REB37E	RHB32S RHB36S	REB36S	J35, K35, M35					
Pezetel PZLM-18A Dromader						Cont IO-470-C (250 hp)	12	RHM38E	REM40E REM38E	RHM38S	REM38S
PZL-ASZ-621R (1000 hp)	18	RHB37E	REB37E	RHB36S	REB36S	N35, P35, G33					
Pezetel M-21 Dromader Mini						Cont IO-470-N (260 hp)	12	RHB32E		RHB36S RHB32S	
PZL-3S (600 hp)	14	RHB37E	REB37E	RHB36S	REB36S	S-35, V-35, V35A, V35B				RHB36S RHB32S	
Super A9 Quail						Cont IO-520-B (285 hp)	12	RHB32E		RHB36S	
LycO IO-540 (290 hp)	12	RHM38E	REM38E	RHM38S	REM38S	V35TC, V35A-TC, V35B-TC				RHB36S	
B1A Snipe						Cont TSIO-520-D (285 hp)	12	RHB32E		RHB32S	
P&W R985 (450 hp)	18	RHM40E	REM37BY REM40E	RHM38S	REM38S	36, A36				RHB36S RHB32S	
B1A Snipe						Cont IO-520-B (285 hp)	12	RHB32E		RHB36S	
LycO IO-720 (400 hp)	16	RHM38E	REM38E	RHM38S	REM38S	B36TC				RHB36S	
S2A						Cont TSIO-520-UB (300 hp)	12	RHB32E		RHB32S	
Cont W-670 (220 hp)	14	RHM40E	REM40E	RHM38S	REM38S	36B, 550				RHB36S RHB32S	
S2B, S2C, 600-S2C						Cont IO-550-B (300 hp)	12	RHB32E		RHB36S	
P&W R985 (450 hp)						Twin Bonanza B50					
R-1340 (600 hp)	18	RHM40E	REM37BY REM40E	RHM38S	REM38S	2/LycO GO-435-C (260 hp)	12	RHM40E RHM38E	REM40E REM38E	RHM38S	REM38S
						C50					
						2/LycO GO-480-F (275 hp)	12	RHM40E RHM38E	REM40E REM38E	RHM38S	REM38S
						D50, D50A					
						1/2" Rch. Cyl. 2/LycO GO-480-C, G (295 hp)	12	RHM38E	REM38E	RHM38S	REM38S
						D50, D50A					
						13/16" Rch. Cyl. 2/LycO GO-480-G (295 hp)	12	RHB37E		RHB36S	

Most generally used plugs shown in red type. For Unshielded Spark Plugs - see pgs. 13-16. Plug Listings taken from FAA Approved Data. Please consult your aviation distributor for availability on these items.

4 Contact your preferred distributor for Champion factory FAA certified servicing of your spark plugs.

Spark Plugs



Popular Aircraft and Engines

U.S. Aircraft/Engine Specifications	Plugs Per Eng.	Massive		Fine Wire		U.S. Aircraft/Engine Specifications	Plugs Per Eng.	Massive		Fine Wire	
		Shielded						Shielded			
		3/4"-20	5/8"-24	3/4"-20	5/8"-24			3/4"-20	5/8"-24	3/4"-20	5/8"-24
BEECH (Cont'd) E50, F50 1/2" Rch. Cyl. 2/LycO GSO-480-A, -B (340 hp)	12	RHM38E	REM38E	RHM38S	REM38S	Musketeer A23, 23 Custom III A23A Cont IO-346-A (165 hp)	8	RHM40E		RHM38S	
E50, F50 13/16" Rch. Cyl. 2/LycO GSO-480-A, -B (340 hp)	12	RHB37E		RHB36S		24 Super III, A24, A24R, B24R, C-24R Sierra LycO IO-360 (200 hp)	8	RHM38E	REM38E	RHM38S	REM38S
G50, H50, J50 1/2" Rch. Cyl. 2/LycO IGSO-480-A (340 hp)	12	RHM38E	REM38E	RHM38S	REM38S	Duchess 76 2/LycO. IO-360-E1A6D & O-360-E1A6D (180 hp)	8	RHM40E RHM38E	REM40E REM38E	RHM38S	REM38S
G50, H50, J50 3/16" Rch. Cyl. 2/LycO IGSO-480-A (340 hp)	12	RHB37E RHB32E		RHB36S RHB32S		Skipper 77 LycO O-235-L2C (115 hp)	8	RHM40E RHM38E	REM40E REM38E	RHM38S	REM38S
Travel Air 95, B95 2/LycO O-360-A (180 hp)	8	RHM40E RHM38E	REM40E REM38E	RHM38S	REM38S	BELL Utility 47G, 47H, 47H-1 Frank 6V4-200 (200 hp)	12			REL37B	
Travel Air B95A, D95A, E95 2/LycO IO-360-B (180 hp)	8	RHM40E RHM38E	REM40E REM38E	RHM38S	REM38S	47G-2, 47G-2A, 47G-5, 47J, 47K 1/2" Rch. Cyl. LycO VO-435 (260 hp)	12	RHM40E RHM38E	REM40E REM38E	RHM38S	REM38S
Debonair B33, A33 Cont IO-470-J (225 hp)	12	RHM40E	REM40E	RHM38S	REM38S	47G-2, 47G-2A, 47G-5, 47J, 47K 13/16" Rch. Cyl. LycO VO-435 (260 hp)	12	RHB37E		RHB36S	
Debonair B33, C33, D33, E33B Cont IO-470-K (225 hp)	12	RHM40E	REM40E	RHM38S	REM38S	Ranger 47J-2, 47J-2A LycO VO-540-B (305 hp)	12	RHM38E	REM38E	RHM38S	REM38S
Debonair C33A, E33A, E33C Cont IO-520-B (285 hp)	12	RHB32E		RHB36S RHB32S		Bellarus 47H, 47H-1 Frank 6V4-200-C32 (200 hp)	12			REL37B	
Baron 55, A55, B55, B55B 2/Cont IO-470-L (260 hp)	12	RHB32E		RHB36S RHB32S		Utility 47G-3B 1/2" Rch. Cyl. LycO TVO-435-A (260 hp)	12	RHM38E	REM38E	RHM38S	REM38S
Baron 55, A55, B55, E55 2/Cont IO-520-C (285 hp)	12	RHB32E		RHB36S RHB32S		Utility 47G-3B 13/16" Rch. Cyl. LycO TVO-435-A (260 hp)	12	RHB37E RHB32E		RHB36S RHB32S	
Baron 56TC 2/LycO TIO-541-E1B4 (380 hp)	12	RHB37E RHB32E		RHB36S RHB32S		Utility 47G-3B1, -3B2 LycO TVO-435-B, -C (270/280 hp)	12	RHB37E RHB32E		RHB36S RHB32S	
Baron 58, 58A 2/Cont IO-520-C, -CB (285 hp)	12	RHB32E		RHB36S RHB32S		Utility 47G-3 Frank 6VS-335 (225 hp)	12	RHB37E RHB32E	REB37E	RHB36S	REB36S
Baron 58P, 58TC 2/Cont TSIO-520-L, -WB (310/325 hp)	12	RHB32E		RHB36S RHB32S		Utility 47G-4, 47G-4A LycO VO-540-B1B (305 hp)	12	RHM38E	REM38E	RHM38S	REM38S
Baron 58C 2/Cont IO-550C (300 hp)	12	RHB32E		RHB36S RHB32S		Utility 47G-5, 47G-5A 13/16" Rch. Cyl. LycO VO-435-B1A (265 hp)	12	RHB37E		RHB36S	
Duke 60, A60, B60 2/LycO TIO-541-E1A4 (380 hp)	12	RHB37E RHB32E		RHB36S RHB32S		BELLANCA 14-13 Series Frank 6A4-A150 (150 hp) Frank 6A4-165 (165 hp)	12			REJ38	
Queen Air 65, 70 1/2" Rch. Cyl. 2/LycO IGSO-480-A (340 hp)	12	RHM38E	REM38E	RHM38S		14-19 LycO O-435-A (190 hp)	12	RHM40E	REM40E	RHM38S	REM38S
Queen Air 65, 70 13/16" Rch. Cyl. 2/LycO IGSO-480-A (340 hp)	12	RHB37E RHB32E		RHB36S RHB32S		14-19-3, 3A, 260B Cont IO-470-F (260 hp)	12	RHB32E		RHB36S RHB32S	
Queen Air 80, 88, B80 2/LycO IGSO-540-A (380 hp)	12	RHB37E RHB32E		RHB36S RHB32S		17-30, 17-30A Cont IO-520-D, -K (300 hp)	12	RHB32E		RHB36S RHB32S	
Musketeer, Sport III, B19 Sport LycO O-320-A, -E (150 hp)	8	RHM40E	REM37BY REM40E	RHM38S	REM38S	17-31, 17-31A LycO IO-540-G, K Series (290/300 hp)	12	RHB37E RHB32E	REM38E	RHB36S RHM32S	
Musketeer 23 LycO O-320-D2B (160 hp)	8	RHM40E	REM37BY REM40E	RHM38S	REM38S			RHM38E		RHM38S	REM38S
Musketeer A23-19A C23 Sundowner LycO O-360-A (180 hp)	8	RHM40E RHM38E	REM37BY REM40E REM38E	RHM38S	REM38S						

Most generally used plugs shown in **red** type. For Unshielded Spark Plugs - see pgs. 13-16. Plug Listings taken from FAA Approved Data. Please consult your aviation distributor for availability on these items.



Spark Plugs

Popular Aircraft and Engines

U.S. Aircraft/Engine Specifications	Plugs Per Eng.	Massive		Fine Wire		U.S. Aircraft/Engine Specifications	Plugs Per Eng.	Massive		Fine Wire	
		Shielded						Shielded			
		3/4"-20	5/8"-24	3/4"-20	5/8"-24			3/4"-20	5/8"-24	3/4"-20	5/8"-24
BELLANCA (Cont'd) 17-31TC, 17-31ATC Lyco IO-540-G Series, K1E5 (290/300 hp)	12	RHB37E RHB32E		RHB36S RHB32S		CESSNA 120, 140 Cont C-85 (85 hp) Cont C-90 (95 hp)	8	RHM40E	REM37BY REM40E	RHM38S	REM38S
17-31TC Lyco IO-540-K (300 hp)	12	RHB37E RHB32E		RHB36S RHB32S		150, A thru M Cont O-200A (100 hp)	8	RHM40E	REM37BY REM40E	RHM38S	REM38S
BELLANCA (Champion) 7AC-S7AC Cont A65-8 (65 hp)	8	RHM40E	REM37BY REM40E		REM38S	152, F152 Lyco O-235-L2C, N2C (110 hp)	8	RHM40E RHM38E	REM37BY REM40E REM38E	RHM38S	REM38S
7DC, S7DC Cont C-85-8 (85 hp)	8	RHM40E	REM37BY REM40E		REM38S	162 TCM O-200-D	8	RHM40E	REM37BY REM40E	RHM38S	REM38S
S7CCM, 7EC, S7EC, 7FC, 7JC Cont C-90-12 (90 hp)	8	RHM40E	REM37BY REM40E	RHM38S	REM38S	170, 170A, B Cont C-145 (145 hp) O-300 (145 hp)	12	RHM40E	REM37BY REM40E	RHM38S	REM38S
7GC, 7HC Lyco O-290-D (135 hp)	8	RHM40E	REM40E	RHM38S	REM38S	172, A-H, Skyhawk Cont O-300 (145 hp)	12	RHM40E	REM37BY REM40E	RHM38S	REM38S
7GCA, 7GCB, 7GCBA, 7GCAA, 7GCBC, 7KC Lyco O-320-A (150 hp)	8	RHM40E	REM37BY REM40E	RHM38S	REM38S	172 I-M Skyhawk Lyco O-320-E (150 hp)	8	RHM40E	REM37BY REM40E	RHM38S	REM38S
7ACA Frank 2A-120-B (50 hp)	4	RHB32E		RHB36S		172N, F172N Skyhawk/100 Lyco O-320-H2AD (160 hp)	8	RHM40E RHM38E	REM37BY REM40E REM38E	RHM38S	REM38S
7ECA Lyco O-235 (108 hp) Cont O-200-A (100 hp)	8	RHM40E	REM37BY REM40E	RHM38S	REM38S	172P Skyhawk Lyco O-320-D2J (160 hp)	8	RHM40E RHM38E	REM37BY REM40E REM38E	RHM38S	REM38S
7ECA Lyco O-235-K (118 hp)	8	RHM38E	REM37BY REM38E	RHM38S	REM38S	P172, Powermatic Cont GO-300-E (175 hp)	12	RHM40E RHM38E	REM40E REM38E	RHM38S	REM38S
7KCAB Lyco IO-320-E (150 hp) AEIO-320-E (150 hp)	8	RHM40E	REM37BY REM40E	RHM38S	REM38S	R172K, FR172K Hawk XP Cont IO-360-K (195 hp)	12	RHM38E	REM38E	RHM38S	REM38S
8KCAB Lyco IO-320-E (150 hp) AEIO-320-E (150 hp)	8	RHM40E	REM37BY REM40E	RHM38S	REM38S	R172R & S Lyco IO-360-L2A (160/180 hp)	8	RHM38E RHM40E	REM38E REM40E	RHM38S	REM38S
8GCBC Super Scout Lyco O-360-C Series (180 hp)	8	RHM40E RHM38E	REM37BY REM40E REM38E	RHM38S	REM38S	172RG Cutlass RG Lyco O-360-F1A6 (180 hp)	8	RHM40E RHM38E	REM37BY REM40E REM38E	RHM38S	REM38S
8KCAB Lyco AEIO-360-H1A (180 hp)	8	RHM40E RHM38E	REM40E REM38E	RHM38S	REM38S	172G Cutlass II Lyco O-360-A4H (180 hp)	8	RHM40E RHM38E	REM37BY REM40E REM38E	RHM38S	REM38S
BRANTLY B2 Lyco VO-360 (180 hp) IVO-360 (180 hp)	8	RHM40E RHM38E	REM40E REM38E	RHM38S	REM38S	175A, B, C, Skylark Cont GO-300-A thru E (175 hp)	12	RHM40E RHM38E	REM37BY REM40E REM38E	RHM38S	REM38S
B2B IVO-360A (180 hp)	8	RHB37E		RHB36S		175 Frank 6A-335-B (180 hp)	12	RHB32E		RHB36S	
305 Lyco IVO-540-A1A (305 hp)	12	RHB37E		RHB36S		177, Cardinal Lyco O-320-E (150 hp)	8	RHM40E	REM37BY REM40E	RHM38S	REM38S
CALL-AIR A, A-2, A-4 Lyco O-235 (115 hp) Lyco O-290 (140 hp)	8	RHM40E	REM40E	RHM38S	REM38S	177A, 177B, Cardinal Lyco O-360-A1F6D (180 hp)	8	RHM40E RHM38E	REM37BY REM40E REM38E	RHM38S	REM38S
A-5 Lyco O-320-A (150 hp)	8	RHM40E	REM37BY REM40E	RHM38S	REM38S	Cardinal RG Lyco IO-360-A1B6D (200 hp)	8	RHM38E	REM38E	RHM38S	REM38S
A-6 Lyco O-360-A (180 hp)	8	RHM40E RHM38E	REM37BY REM40E REM38E	RHM38S	REM38S	180 Cont O-470-A, -J (225 hp)	12	RHM40E	REM40E	RHM38S	REM38S
A-7, A7T Cont W-670 (240 hp)	14	RHM40E	REM40E	RHM38S	REM38S	180A thru D Cont O-470-K, -L (230 hp)	12	RHM40E	REM40E	RHM38S	REM38S
						180E, F, G, H, J Cont O-470-R, -S (230 hp)	12	RHM40E	REM40E	RHM38S	REM38S
						180K Cont O-470-U (230 hp)	12	RHB32E		RHB36S RHB32S	

Most generally used plugs shown in red type. For Unshielded Spark Plugs - see pgs. 13-16. Plug Listings taken from FAA Approved Data. Please consult your aviation distributor for availability on these items.

6 Contact your preferred distributor for Champion factory FAA certified servicing of your spark plugs.

Spark Plugs



Popular Aircraft and Engines

U.S. Aircraft/Engine Specifications	Plugs Per Eng.	Massive		Fine Wire		U.S. Aircraft/Engine Specifications	Plugs Per Eng.	Massive		Fine Wire	
		Shielded						Shielded			
		3/4"-20	5/8"-24	3/4"-20	5/8"-24			3/4"-20	5/8"-24	3/4"-20	5/8"-24
CESSNA (Cont'd)						207, A					
182A thru D, Skylane Cont O-470-L (230 hp)	12	RHM40E	REM40E	RHM38S	REM38S	Cont IO-520-F (300 hp)	12	RHB32E		RHB32S	
182E thru P, Skylane Cont O-470-R, -S (230 hp)	12	RHM40E	REM40E	RHM38S	REM38S	T207, A Cont TSIO-520-G, -M (285 hp)	12	RHB32E		RHB36S	RHB32S
182Q, R, F182Q, R, Skylane Cont O-470-U (230 hp)	12	RHB32E		RHB36S	RHB32S	210, 210A, 210B, 210C Cont IO-470-E, -S (260 hp)	12	RHB32E		RHB36S	RHB32S
R182, FR182 Skylane RG Lyco O-540-J3C5D (235 hp)	12	RHM40E	REM40E	RHM38E	REM38E	210 Centurion, 210K, L, M, N, R Cont IO-520-A, -J, -L (285/300 hp)	12	RHB32E		RHB36S	RHB32S
T182 Turbo Skylane Lyco O-540-L3C5D (235 hp)	12	RHB37E		RHB36S	RHB32S	T210 Centurion, T210K, L, M, N Cont TSIO-520-C, -H, -R (285 hp)	12	RHB32E		RHB36S	RHB32S
C-182 IO-540-AB1A5 (230 hp)	12	RHM38E	REM38E	RHM38S	REM38S	P210N, Pressurized Centurion Cont TSIO-520-P, PA, AF, CE (310 hp)	12	RHB32E		RHB36S	RHB32S
T-182 TIO-540-AJ1A	12	RHB37E		RHB36S	RHB32S	T303, Crusader 2/Cont TSIO-520-AE & LTSIO-520-AE (250 hp)	12	RHB32E		RHB36S	RHB32S
TR182, FTR182-Turbo Skylane RG Lyco O-540-L3C5D (235 hp)	12	RHB37E		RHB36S	RHB32S	310 2/Cont O-470-B (240 hp)	12	RHM40E	REM40E	RHM38S	REM38S
185, A thru E Skywagon Cont IO-470-F (260 hp)	12	RHB32E		RHB36S	RHB32S	310A 2/Cont O-470-M (240 hp)	12	RHM40E	REM40E	RHM38S	
185F, A185E/F Skywagon & AG Carry (All) Cont IO-520-D (300 hp)	12	RHB32E		RHB36S	RHB32S	310C, D, F thru M, P, Q 2/Cont IO-470-D, -U, -V, -VO (260 hp)	12	RHB32E		RHB36S	RHB32S
188 Agwagon Cont O-470-R (230 hp)	12	RHM40E	REM40E	RHM38S	REM38S	310R 2/Cont IO-520-M (285 hp)	12	RHB32E		RHB36S	RHB32S
188 Agpickup Cont O-470-S (230 hp)	12	RHM40E	REM40E	RHM38S	REM38S	T310P, T310Q, T310R 2/Cont TSIO-520-B (285 hp)	12	RHB32E		RHB36S	RHB32S
188, A188B Agwagon Cont IO-520-D (300 hp)	12	RHB32E		RHB36S	RHB32S	320A, B, C, Skynight 2/Cont TSIO-470-B, -C, -D (260 hp)	12	RHB32E		RHB36S	RHB32S
188 Agtruck Cont IO-520-D (300 hp)	12	RHB32E		RHB36S	RHB32S	320D, E, F, Executive Skynight 2/Cont TSIO-520-B (285 hp)	12	RHB32E		RHB36S	RHB32S
T188C Aghusky Cont TSIO-520-T (310 hp)	12	RHB32E		RHB36S	RHB32S	335 2/Cont TSIO-520-EB (300 hp)	12	RHB32E		RHB36S	RHB32S
190 Cont W-670 (240 hp)	14	RHM40E	REM40E	RHM38S	REM38S	336, 337 Skymaster 2/Cont IO-360-G (210 hp)	12	RHM38E		RHM38S	
195 Jacobs R-755 (245/275/300 hp)	14	RHM40E	REM40E	RHM38S	REM38S	337 Super Skymaster 2/Cont TSIO-360 (210 hp)	12	RHM38E		RHM38S	
205, 205A Cont IO-470-S (260 hp)	12	RHB32E		RHB36S	RHB32S	P337G/H Pressurized Skymaster 2/Cont TSIO-360-C (225 hp)	12	RHM38E		RHM38S	
C-206-H IO-540-AC1A5 (300 hp)	12	RHB37E		RHB36S	RHB32S	T337H Turbo Skymaster 2/Cont TSIO-360-H (210 hp)	12	RHM38E		RHM38S	
T-206-H TIO-540-AJ1A (310 hp)	12	RHB32E		RHB36S	RHB32S	340 2/Cont TSIO-520-K (285 hp)	12	RHB32E		RHB36S	RHB32S
P206 Super Skylane Cont IO-520-A (285 hp)	12	RHB32E		RHB36S	RHB32S	340A 2/Cont TSIO-520-N (310 hp)	12	RHB32E		RHB36S	RHB32S
TP206 Super Skylane Cont TSIO-520-C (285 hp)	12	RHB32E		RHB36S	RHB32S	350 Corvalis TCM 10-550-N	12	RHB32E		RHB32S	
U206 Super Skywagon						400 Corvalis TT TCM TS10-550-C	12	RHB32E		RHB32S	
U206D Cont IO-520-A (285 hp) Cont IO-520-F (300 hp)	12	RHB32E		RHB36S	RHB32S						
U206E, U206G Stationair, U206F Cont IO-520-F (300 hp)	12	RHB32E		RHB36S	RHB32S						
TU206 Super Skywagon Cont TSIO-520-C (285 hp)	12	RHB32E		RHB36S	RHB32S						
TU206E, TU206G, TU206F G Stationair Cont TSIO-520-C, M (285/310 hp)	12	RHB32E		RHB36S	RHB32S						

Most generally used plugs shown in red type. For Unshielded Spark Plugs - see pgs. 13-16. Plug Listings taken from FAA Approved Data. Please consult your aviation distributor for availability on these items.



Spark Plugs

Popular Aircraft and Engines

U.S. Aircraft/Engine Specifications	Plugs Per Eng.	Massive		Fine Wire		U.S. Aircraft/Engine Specifications	Plugs Per Eng.	Massive		Fine Wire	
		Shielded		Shielded				Shielded		Shielded	
		3/4"-20	5/8"-24	3/4"-20	5/8"-24			3/4"-20	5/8"-24	3/4"-20	5/8"-24
CESSNA (Cont'd)						GRUMMAN (Cont'd)					
401, 402A, B 2/Cont TSIO-520-E	12	RHB32E		RHB36S RHB32S		Widgeon G44 2/Ranger 6-440-C5 (200 hp)	12	RHM40E	REM40E	RHM38S	REM38S
402C 2/Cont TSIO-520-VB (325 hp)	12	RHB32E		RHB36S RHB32S		Modified G44 2/Cont IO-470-M (260 hp)	12	RHB32E			RHB36S RHB32S
404 Titan 2/Cont GTSIO-520-M (375 hp)	12	RHB32E		RHB36S RHB32S		Modified G44 2/Lyco GO-480-B (270 hp)	12	RHM40E RHM38E	REM40E REM38E	RHM38S	REM38S
411, 411A 2/Cont GTSIO-520-C (340 hp)	12	RHB32E		RHB36S RHB32S		Mallard G-73 2/P & W R-1340 (600 hp)	18	RHM40E	REM40E	RHM38S	REM38S
414, 414A 2/Cont TSIO-520-J, -N (310 hp)	12	RHB32E		RHB36S RHB32S		Avenger TBM Wright R-2600 (1900 hp)	28	RHB37E	REB37E	RHB36S	REB36S
421A, B, C 2/Cont GTSIO-520-D, -H, -L -N (375 hp)	12	RHB32E		RHB36S RHB32S		GULFSTREAM AMERICAN					
CHAMPION (See Bellanca)						AA-1 Yankee Lyco O-235 (108 hp)	8	RHM40E	REM40E	REM37BY RHM38S	REM38S
CHRISTEN						AA-1A, AA-1B Trainer Lyco O-235 (108 hp)	8	RHM40E	REM40E	REM37BY RHM38S	REM38S
S-1T Pitts Special Lyco AEIO-360-A1E (200 hp)	8	RHM38E	REM38E	REM37BY RHM38S	REM38S	AA-1B, TR2 Lyco O-235 (108 hp)	8	RHM40E	REM40E	REM37BY RHM38S	REM38S
S-2B, S-2S Pitts Special Lyco AEIO-540-D4A5 (260 hp)	12	RHM40E RHM38E	REM40E REM38E	RHM38S	REM38S	AA1C Lynx, T-Cat Lyco O-235-L (115 hp)	8	RHM40E RHM38E	REM40E REM38E	RHM38S	REM38S
CIRRUS						AA-5 Traveler Lyco O-320-E (150 hp)	8	RHM40E	REM40E	REM37BY RHM38S	REM38S
SRV, SR20 Cont. IO360-ES (200 hp)	8	RHM38E	REM38E	RHM38S	REM38S	AA5A Cheetah Lyco O-320-E (150 hp)	8	RHM40E	REM40E	REM37BY RHM38S	REM38S
SR22 Cont. IO550-N (310 hp)	12	RHB32E		RHB36S RHB32S		AA-5B Tiger Lyco O-360-A4K (180 hp)	8	RHM40E RHM38E	REM37BY REM38E	REM40E RHM38S	REM38S
COLUMBIA/LANCAIR						Cougar 2/Lyco O-320-D (160 hp)	8	RHM40E RHM38E	REM37BY REM40E	REM38E RHM38S	REM38S
Columbia 300, 350 Cont IO550N (310 hp)	12	RHB32E		RHB32S RHB36S		COMMANDER					
Columbia 400 Cont TSIO550 (310 hp)	12	RHB32E		RHB32S RHB36S		Commander 200D Cont IO-520-A (285 hp)	12	RHB32E		RHB32S	
COMMANDER AIRCRAFT COMPANY						500 2/Lyco O-540-A (250 hp)	12	RHM40E RHM38E	REM40E REM38E	RHM38S	REM38S
Commander 114B Lyco IO-540-T4B5 (260 hp)	12	RHM40E RHM38E	REM40E REM38E	RHM38S	REM38S	500A 2/Cont IO-470-M (260 hp)	12	RHB32E		RHB32S	
Commander 114TCL TSIOL-550B	12	RHU32E			RHU32S	500B, 500U, 500S 2/Lyco IO-540-B, -E 1/2" Rch. Cyl. (290 hp)	12	RHM38E	REM38E	RHM38S	REM38S
DIAMOND						500U 2/Lyco IO-540-E1B5 13/16" Rch. Cyl. (290 hp)	12	RHB37E RHB32E	REB37E REB32E	RHB36S RHB32S	REB36S
Eclipse Evolution						520 2/Lyco GO-435-C (260 hp)	12	RHM40E RHM38E	REM40E REM38E	RHM38S	REM38S
DA 20-1C Cont. IO240B3B (125 hp)	8	RHM38E	REM38E	RHM38S	REM38S	BY560 2/Lyco GO-480-B (270 hp) GO-480-D (275 hp)	12	RHM40E RHM38E	REM40E REM38E	RHM38S	REM38S
DA 40-180 Lyco IO360-MIA (180 hp)	8	RHM38E	REM37BY REM40E REM38E	RHM38S	REM38S	560A, E 1/2" Rch. Cyl. 2/Lyco GO-480-C, -G (295 hp)	12	RHM38E	REM38E	RHM38S	REM38S
ENSTROM						560A, E 13/16" Rch. Cyl. 2/Lyco GO-480-G (295 hp)	12	RHB37E		RHB36S	
F28, F28A, 280 Lyco HIO-360-C (205 hp)	8	RHM38E	REM38E	RHM38S	REM38S	560F 1/2" Rch. Cyl. 2/Lyco IGO-540 (350 hp)	12	RHM38E		RHM36S	
F28B Lyco TIO-360-B2A (200 hp)	8	RHB37E	REB37E	RHB36S	REB36S						
F28C, 280C Lyco HIO-360-E1AD (205 hp)	8	RHB32E			RHB32S						
F28E, F28F Lyco IO-360-F1AD (225 hp)	8	RHB32E			RHB32S						
ERCOUPE											
Club-Air 415-C Cont C-75 (75 hp)	8	RHM40E	REM37BY REM40E								
Club-Air 415E, F, G, H Cont C-85 (85 hp)	8	RHM40E	REM37BY REM40E								
GRUMMAN											
Goose 21 2/P & W R-985 (450 hp)	18	RHM40E	REM40E	RHM38S	REM38S						

Most generally used plugs shown in red type. For Unshielded Spark Plugs - see pgs. 13-16. Plug Listings taken from FAA Approved Data. Please consult your aviation distributor for availability on these items.

8 Contact your preferred distributor for Champion factory FAA certified servicing of your spark plugs.

Spark Plugs



Popular Aircraft and Engines

U.S. Aircraft/Engine Specifications	Plugs Per Eng.	Massive		Fine Wire		U.S. Aircraft/Engine Specifications	Plugs Per Eng.	Massive		Fine Wire	
		Shielded						Shielded			
		3/4"-20	5/8"-24	3/4"-20	5/8"-24			3/4"-20	5/8"-24	3/4"-20	5/8"-24
COMMANDER (Cont'd)						UH-12D					
560F 13/16" Rch. Cyl. 2/LycO IGO-540 (350 hp)	12	RHB37E		RHB36S		LycO VO-435 (260 hp)	12	RHM40E RHM38E	REM40E REM38E	RHM38S	REM38S
680, 680E						UH-12E					
1/2" Rch. Cyl. 2/LycO GSO-480-A (340 hp)	12	RHM38E	REM38E	RHM38S	REM38S	1/2" Rch. Cyl. LycO VO-540 (305 hp)	12	RHM38E	REM38E	RHM38S	REM38S
680, 680E						UH-12E, L					
13/16" Rch. Cyl. 2/LycO GSO-480-A (340 hp)	12	RHB37E		RHB36S		13/16" Rch. Cyl. LycO VO-540-C (305 hp)	12	RHB37E		RHB36S	
680F, 680FP, 680FL, 680FLP						HUSKY					
1/2" Rch. Cyl. 2/LycO IGSO-540-B (380 hp)	12	RHM38E		RHM38S		A-1B-160	8	RHM38E	REM38E	RHM38S	REM38S
680F, 680FP, 680FL, 680FLP						Lyc. 0-320-D2A			REM37BY	RHM38S	REM38S
13/16" Rch. Cyl. 2/LycO IGSO-540-B (380 hp)	12	RHB37E RHB32E		RHB36S RHB32S		A-1B-180	8	RHM38E	REM38E	RHM38S	REM38S
112, 112A						Lyc. 0-360-A1P			REM37BY	RHM38S	REM38S
LycO IO-360-C (200 hp)	8	RHM38E	REM38E	RHM38S	REM38S	A-1B-200	8	RHM38E	REM38E	RHM38S	REM38S
112TC, 112TCA						Lyc. 10-360-A1D6			REM37BY	RHM38S	REM38S
LycO TO-360-C1A6D (210 hp)	8	RHB32E		RHB32S		LAKE					
114, 114A						200EP					
LycO IO-540-T4A5D (260 hp)	12	RHM40E RHM38E	REM40E REM38E	RHM38S	REM38S	LycO IO-360-A1B6 (200 hp)	8	RHM38E	REM38E	RHM38S	REM38S
Commander 685						LA-250	12	RHM40E	REM40E	RHM38S	
2/Cont GTSIO-520-F, -K (435 hp)	12	RHB32E		RHB32S		LycO IO-540-C4B5 (250 hp)	12	RHM38E	REM38E	RHM38S	
Model 700						Skimmer C-1	8	RHM40E	REM40E	RHM38S	REM38S
2/LycO TIO-540-R2AD (340/350 hp)	12	RHB37E RHB32E	REB37E REB32E	RHB36S RHB32S	REB36S	Skimmer C-2, LA-4, LA-4A	8	RHM40E RHM38E	REM40E REM38E	RHM38S	REM38S
HELIO						LycO O-360-A (180 hp)	8	RHM40E	REM40E	RHM38S	REM38S
Courier						Skimmer LA-4-200	8	RHM38E	REM38E	RHM38S	REM38S
LycO GO-435-C (260 hp)	12	RHM40E RHM38E	REM40E REM38E	RHM38S	REM38S	LUSCOMBE					
Super Courier						Silvaire 8A	8	RHM40E	REM37BY REM40E		
1/2" Rch. Cyl. LycO GO-480-G (295 hp)	12	RHM38E	REM38E	RHM38S	REM38S	Cont A-65 (65 hp)			REM37BY REM40E	RHM38S	REM38S
Strato Courier						Silvaire 8C, D	8	RHM40E	REM40E	RHM38S	REM38S
1/2" Rch. Cyl. LycO GSO-480-A (340 hp)	12	RHM38E	REM38E	RHM38S	REM38S	Cont A-75 (75 hp)			REM37BY REM40E	RHM38S	REM38S
Strato Courier						Silvaire 8E, F	8	RHM40E	REM37BY REM40E	RHM38S	REM38S
13/16" Rch. Cyl. LycO GSO-480-A (340 hp)	12	RHB37E		RHB36S		Cont C-85 (85 hp) Cont C-90 (95 hp)			REM37BY REM40E	RHM38S	REM38S
Caballero						Sedan 1A	12	RHM40E	REM40E	RHM38S	REM38S
LycO O-540-A (250 hp)	12	RHM40E RHM38E	REM40E REM38E	RHM38S	REM38S	McCULLOCH					
Helio 700						J-2	8	RHM40E RHM38E	REM37BY REM40E REM38E	RHM38S	REM38S
LycO TIO-540-J2BD (350 hp)	12	RHB37E RHB32E		RHB36S RHB32S		MAULE					
Helio 800						M4 Astro Rocket	12	RHB32E		RHB32S	
LycO IO-720-A1B (400 hp) (Long Reach)	16	RHB37E RHB32E	REB37E REB32E	RHB36S RHB32S	REB36S	M4 Jetasen	12	RHM40E RHM38E	REM40E REM38E	RHM38S	REM38S
Helio 800						Cont O-300A (145 hp)			REM38E	RHM38S	REM38S
LycO IO-720-A1B (400 hp) (Short Reach)	16	RHM38E	REM38E	RHM38S	REM38S	M4 Rocket	12	RHM38E	REM38E	RHM38S	REM38S
Helio Twin						Cont IO-360-A (210 hp)					
2/LycO O-540-A (250 hp)	12	RHM40E RHM38E	REM40E REM38E	RHM38S	REM38S	M4 Strata Rocket	12	RHB32E		RHB32S	
Twin Courier						Frank 6A-350C (220 hp)					
2/LycO O-540-A (250 hp)	12	RHM40E RHM38E	REM40E REM38E	RHM38S	REM38S	M5-180C, MX7-180	8	RHM40E RHM38E	REM40E REM38E	RHM38S	REM38S
HILLER						LycO O-360-C, O-360-C1F (180 hp)					
UH-12B						M5-210C	12	RHM38E	REM38E	RHM38S	REM38S
Frank 6V4-200 (200 hp)	12		REL37B			Cont IO-360D (210 hp)					
UH-12C						M5-210TC	8	RHB37E RHB32E	REB37E REB32E	RHB36S	REB36S
Frank 6V-335 (210 hp)	12		REL37B			LycO TO-360-C1A6D (210 hp)					
						M5-235C, M6-235, M7-235					
						LycO O-540-J1A5D (235 hp)	12	RHM40E RHM38E	REM40E REM38E	RHM38S	REM38S
						MX-7-235	12	RHM40E RHM38E	REM40E REM38E	RHM38S	REM38S
						LycO O-540-W1A5D (235 hp)					

Most generally used plugs shown in red type. For Unshielded Spark Plugs - see pgs. 13-16. Plug Listings taken from FAA Approved Data. Please consult your aviation distributor for availability on these items.



Spark Plugs

Popular Aircraft and Engines

U.S. Aircraft/Engine Specifications	Plugs Per Eng.	Massive		Fine Wire		U.S. Aircraft/Engine Specifications	Plugs Per Eng.	Massive		Fine Wire	
		Shielded						Shielded			
		3/4"-20	5/8"-24	3/4"-20	5/8"-24			3/4"-20	5/8"-24	3/4"-20	5/8"-24
MEYERS						H					
MAC-145 Cont C-145 (145 hp)	12	RHM40E	REM37BY REM40E	RHM38S	REM38S	Cont IO-520 (285 hp)	12	RHB32E		RHB32S	RHB32S
200 Cont O-470-M (240 hp)	12	RHM40E RHM38E	REM40E	RHM38S	REM38S	PIPER					
200A, B, C Cont IO-470-D (260 hp)	12	RHB32E				Cub J3, J4, J5, PA-11, PA-17 Cont A-65 (65 hp) C-75 (75 hp)	8	RHM40E	REM37BY REM40E		
MOONEY						J3, J4, J5, PA-15 Lyco O-145 (65 hp)	8	RHM40E	REM40E		
M18C, M18L Cont A-65 (65 hp) Lyco O-145 (65 hp)	8	RHM40E	REM37BY REM40E	RHM38S	REM38S	PA-12, PA-14, PA-16 Lyco O-235 (115 hp)	8	RHM40E	REM40E	RHM38S	REM38S
Cadet Cont C-90 (95 hp)	8	RHM40E	REM37BY REM40E	RHM38S	REM38S	Super Cub PA-18 "95" Cont C-90 (95 hp)	8	RHM40E	REM37BY REM40E	RHM38S	REM38S
Encore TSIO-360 (220 hp)		RHM38E	REM38E	RHM38S	REM38S	PA-18 "105" Lyco O-235 (105 hp)	8	RHM40E	REM40E	RHM38S	REM38S
M20 Lyco O-320-A (150 hp)	8	RHM40E	REM37BY REM40E	RHM38S	REM38S	PA-18 "125" Lyco O-235 (105 hp)	8	RHM40E	REM40E	RHM38S	REM38S
M20A Lyco O-360-A Lyco O-360-A1D (180 hp)	8	RHM40E RHM38E	REM37BY REM40E REM38E	RHM38S	REM38S	PA-18 "135" Lyco O-290-D2 (135 hp)	8	RHM40E	REM40E	RHM38S	REM38S
M20B Mark 21 Lyco O-360-A Lyco O-360-A1D (180 hp)	8	RHM40E RHM38E	REM37BY REM40E REM38E	RHM38S	REM38S	PA-18 "150" Lyco O-320-A (150 hp)	8	RHM40E	REM37BY REM40E	RHM38S	REM38S
M20C Ranger Mark 21 Lyco O-360-A1D (180 hp)	8	RHM40E RHM38E	REM37BY REM40E REM38E	RHM38S	REM38S	Pacer PA-20 "115" Lyco O-235-C (115 hp)	8	RHM40E	REM40E	RHM38S	REM38S
M20D Master Lyco O-360-A Lyco O-360-A2D (180 hp)	8	RHM40E RHM38E	REM37BY REM40E REM38E	RHM38S	REM38S	PA-20 "125" Lyco O-290-D (125 hp)	8	RHM40E	REM40E	RHM38S	REM38S
M20E Chaparral						PA-20 "135" Lyco O-290-D2 (135 hp)	8	RHM40E	REM40E	RHM38S	REM38S
Super 21 Lyco IO-360-A1D (200 hp)	8	RHM38E	REM38E	RHM38S	REM38S	PA-22 "108" Colt Lyco O-235-C (108 hp)	8	RHM40E	REM40E	RHM38S	REM38S
M20F Executive Lyco IO-360-A1A (200 hp)	8	RHM38E RHM40E	REM38E REM37BY	RHM38S	REM38S	Tri-Pacer PA-22 "135" Lyco O-290-D2 (135 hp)	8	RHM40E	REM40E	RHM38S	REM38S
M20G Statesman Lyco O-360-A (180 hp)	8	RHM38E	REM40E REM38E	RHM38S	REM38S	PA-22 "150" Lyco O-320-A (150 hp)	8	RHM40E	REM37BY REM40E REM40E	RHM38S	REM38S
M20J-201, 205-MSE Lyco IO-360-A3B6D (200 hp)	8	RHM38E	REM38E	RHM38S	REM38S	PA-22 "160" Lyco O-320-B (160 hp)	8	RHM40E RHM38E	REM38E REM37BY	RHM38S	REM38S
M20K-231 Cont TSIO-360-B, GB1, -GB3, -GB4, LB1 (210 hp)	12	RHM38E	REM38E	RHM38S	REM38S	Apache PA-23 "150" 2/Lyco O-320-A (150 hp)	8	RHM40E	REM37BY REM40E	RHM38S	REM38S
M20K-252, TSE Cont TSIO-360-MB1 (210 hp)	12	RHM38E		RHM38S		PA-23 "160" Lyco O-320-B (160 hp)	8	RHM40E RHM38E	REM38E REM37BY	RHM38S	REM38S
M20M-TLS Bravo Lyco TIO-540-AF1A (270 hp)	12	RHB37E		RHB36S RHB32S		PA-23 "235" 2/Lyco O-540-B (235 hp)	12	RHM40E	REM40E	RHM38S	REM38S
M-20R Ovation TCM-IO-550G (5)	12	RHB32E		RHB32S		Aztec PA-23 "250" 2/Lyco O-540-A (250 hp)	12	RHM40E RHM38E	REM40E REM38E	RHM38S	REM38S
M20S Eagle IO-550G (244 hp)		RHB32E		RHB36S RHB32S		Aztec C, D, E, F, PA-23 "250" 2/Lyco IO-540-C (250 hp) (Short Reach)	12	RHM40E RHM38E	REM40E REM38E	RHM38S	REM38S
M22 Mustang Lyco TIO-541-A1A (310 hp)	12	RHB37E RHB32E		RHB36S RHB32S		Aztec - Turbo-Blown 2/Lyco IO-540-J (250 hp)	12	RHB32E	REB37E	RHB32S	REB36S
NAVION						Aztec C, D, E, F, PA-23 "250" 2/Lyco TIO-540-C (250 hp) (Long Reach)	12	RHB37E RHB32E	REB37E REB32E	RHB36S RHB32S	REB36S
A Cont E-185 (205 hp)	12	RHM40E	REM40E	RHM38S	REM38S	Comanche PA-24 "180" Lyco O-360-A (180 hp)	8	RHM40E RHM38E	REM40E REM38E	RHM38S	REM38S
B Lyco GO-435C (260 hp)	12	RHM38E	REM40E	RHM38S	REM38S	PA-24 "250" Lyco O-540-A (250 hp) IO-540-C (250 hp)	12	RHM40E RHM38E	REM40E REM38E	RHM38S	REM38S
D Cont O-470-P (240 hp)	12	RHM40E	REM40E	RHM38S	REM38S						
E Cont IO-470-C (250 hp)	12	RHM40E RHM38E	REM40E REM38E	RHM38S	REM38S						
F, G Cont IO-470-H (260 hp)	12	RHB32E		RHB36S							

Most generally used plugs shown in red type. For Unshielded Spark Plugs - see pgs. 13-16. Plug Listings taken from FAA Approved Data. Please consult your aviation distributor for availability on these items.

10 Contact your preferred distributor for Champion factory FAA certified servicing of your spark plugs.

Spark Plugs



Popular Aircraft and Engines

U.S. Aircraft/Engine Specifications	Plugs Per Eng.	Massive		Fine Wire		U.S. Aircraft/Engine Specifications	Plugs Per Eng.	Massive		Fine Wire	
		Shielded						Shielded			
		3/4"-20	5/8"-24	3/4"-20	5/8"-24			3/4"-20	5/8"-24	3/4"-20	5/8"-24
PIPER (Cont'd)						Mojave (PA-31P-350)					
PA-24 "260", PA24B, PA24C						2/LycO TIO & LTIO-540-V2AD (360 hp)	12	RHB37E RHB32E		RHB36S RHB32S	
LycO IO-540-B, -D, -N (260 hp)	12	RHM40E RHM38E	REM40E REM38E	RHM38S REM38S	REM38S	Cherokee Six PA-32 "260"	12	RHM40E RHM38E	REM40E REM38E	RHM38S REM38S	REM38S
PA-24 "260" Turbo						LycO O-540-E4B5 (260 hp)	12	RHB32E RHB37E	REB32E REB37E	RHB36S	REB36S
LycO IO-540-R1A5 (260 hp)	12	RHB32E RHB37E	REB32E REB37E	RHB32S RHB36S	REB36S	Cherokee Six PA-32 "300"	12	RHM38E	REM38E	RHM38S	REM38S
PA-24 "400"						LycO IO-540-K1A5 (300 hp)	12	RHM38E	REM38E	RHM38S	REM38S
LycO IO-720-A (400 hp)	16	RHM38E		RHM38S		Cherokee Lance PA-32 "300"					
Pawnee PA-25 "150"						LycO IO-540-K1A5D (300 hp)	12	RHM38E	REM38E	RHM38S	REM38S
LycO O-320-A (150 hp)	8	RHM40E	REM37BY REM40E	RHM38S	REM38S	Cherokee Lance II PA-32 "300" R					
PA-25 "235"						LycO IO-540-K1G5D (300 hp)	12	RHM38E	REM38E	RHM38S	REM38S
LycO O-540-B (235 hp)	12	RHM40E	REM40E	RHM38S	REM38S	PA-32RT-300T Turbo Lance					
PA-25 "260"						LycO TIO-540-S1AD (300 hp)	12	RHB37E		RHB36S	
LycO O-540-G (260 hp)	12	RHM40E RHM38E	REM40E REM38E	RHM38S REM38S	REM38S	Saratoga PA-32-301					
Cherokee PA-28 "140"						LycO IO-540-K1G5 (300 hp)	12	RHM38E	REM38E	RHM38S	REM38S
LycO O-320-E (140 hp)	8	RHM40E	REM37BY REM40E	RHM38S	REM38S	Turbo-Saratoga PA-32-301T					
PA-28 "150" Flight Liner 2+2 Cruiser, Warrior "151"						LycO TIO-540-S1AD (300 hp)	12	RHB37E RHB32E	REB37E REB32E	RHB36S RHB32S	REB36S
O-320-A, -E (150 hp)	8	RHM40E	REM37BY REM40E	RHM38S	REM38S	Saratoga SP PA-32R-301					
PA-28 Warrior II "161" Cadet						LycO IO-540-K1G5 (300 hp)	12	RHM38E	REM38E	RHM38S	REM38S
LycO O-320-B, -D (160 hp)	8	RHM40E RHM38E	REM37BY REM40E	RHM38S REM38E	REM38S	Turbo-Saratoga SP PA-32R-301T					
PA-28 "180" Challenger, Archer						LycO TIO-540-S1AD (300 hp)	12	RHB37E RHB32E	REB37E REB32E	RHB36S RHB32S	REB36S
LycO O-360-A (180 hp)	8	RHM40E RHM38E	REM37BY REM40E REM38E	RHM38S	REM38S	Saratoga SP PA-32R-301					
PA-28 "181" Archer II						LycO IO-540-K1G5 (300 hp)	12	RHM38E	REM38E	RHM38S	REM38S
LycO O-360-A (180 hp)	8	RHM40E RHM38E	REM40E REM38E	RHM38S	REM38S	Turbo-Saratoga SP PA-32R-301T					
PA-28R "180" Arrow						LycO TIO-540-S1AD (300 hp)	12	RHB37E	REB32E	RHB36S	
LycO IO-360-B (180 hp)	8	RHM40E RHM38E	REM40E REM38E	RHM38S	REM38S	Seneca PA-34					
PA-28R Arrow II, III, IV "200"						2/LycO LIO-360-C & IO-360-C (200 hp)	8	RHM38E	REM38E	RHM38S	REM38S
LycO IO-360-C (200 hp)	8	RHM38E	REM38E	RHM38S	REM38S	Seneca II PA-34-200T					
PA-28R Turbo Arrow III, IV						2/Cont TSIO-360-E, EB & LTSIO-360-E (200 hp)	12	RHM38E		RHM38S	
Cont TSIO-360F, FB (200 hp)	12	RHM38E	REM38E	RHM38S	REM38S	Seneca III PA-34-220T					
PA-28 "235" Charger, Pathfinder						2/Cont TSIO-360-KB & LTSIO-360-KB (220 hp)	12	RHM38E		RHM38S	
LycO O-540-B (235 hp)	12	RHM40E	REM40E	RHM38S	REM38S	Pawnee Brave PA-36					
PA-28 "236" Dakota						Cont 6-285-B (285 hp) Tierra Engine	12	RHU27E			
LycO O-540-J3A5D (235 hp)	12	RHM40E RHM38E	REM40E REM38E	RHM38S	REM38S	Pawnee Brave PA-36					
PA-28-201T Turbo Dakota						LycO IO-540-K1G5 (300 hp)	12	RHM38E	REM38E	RHM38S	REM38S
Cont TSIO-360-FB (200 hp)	12	RHM38E		RHM38S		Pawnee Brave PA-36					
Twin Comanche PA-30 "160"						LycO IO-720-D1CD (375 hp)	16	RHB32E RHB37E	REB37E	RHB32S RHB36S	REB36S
2/LycO IO-320-B (160 hp)	8	RHM40E RHM38E	REM37BY REM40E	RHM38S	REM38S	Twin Comanche PA-39					
Navajo PA-31 "300"						2/LycO IO-320-B & LIO-320-B (160 hp)	8	RHM40E RHM38E	REM40E REM38E	RHM38S	REM38S
2/LycO IO-540-M (300 hp)	12	RHB37E	REB37E	RHB36S	REB36S	Twin Comanche PA-39 Turbo					
Navajo PA-31						2/LycO LIO-320-C & IO-320-C (160 hp)	8	RHB37E	REB37E	RHB36S	REB36S
2/LycO TIO-540-A1A, A2C (310 hp)	12	RHB37E RHB32E		RHB36S RHB32S		PA-40					
Navajo PA-31-325C/R						2/LycO IO-320-B & LIO-320B (160 hp)	8	RHM40E RHM38E	REM37BY REM40E REM38E	RHM38S	REM38S
2/LycO TIO-540-F2BD & LTIO-540-F2BD (325 hp)	12	RHB37E RHB32E		RHB36S RHB32S		Tomahawk-Trainer PA-38					
Navajo PA-31 Chieftain						LycO O-235-L2C (112 hp)	8	RHM40E RHM38E	REM37BY REM40E REM38E	RHM38S	REM38S
2/LycO TIO-540-J & LTIO-540-J (350 hp)	12	RHB37E RHB32E		RHB36S RHB32S		Seminole PA-44-180					
PAT-1020						2/LycO LO-360-E1A6D & O-360-E1A6D (180 hp)	8	RHM40E RHM38E	REM40E REM38E	RHM38S	REM38S
LycO TIO-540-J2B (350 hp)	12	RHB37E RHB32E		RHB36S RHB32S							
Navajo PA-31P											
2/LycO TIGO-541-E1A (425 hp)	12	RHB37E RHB32E		RHB36S RHB32S							

Most generally used plugs shown in **red** type. For Unshielded Spark Plugs - see pgs. 13-16. Plug Listings taken from FAA Approved Data. Please consult your aviation distributor for availability on these items.



Spark Plugs

Popular Aircraft and Engines

U.S. Aircraft/Engine Specifications	Plugs Per Eng.	Massive		Fine Wire		U.S. Aircraft/Engine Specifications	Plugs Per Eng.	Massive		Fine Wire	
		Shielded						Shielded			
		3/4"-20	5/8"-24	3/4"-20	5/8"-24			3/4"-20	5/8"-24	3/4"-20	5/8"-24
PIPER (Cont'd)						SIKORSKY					
Turbo-Seminole PA-44-180T 2/LycO TO-360-E1A6D & LTO-360-E1A6D (180 hp)	8	RHB37E RHB32E	REB37E REB32E	RHB36S RHB32S	REB36S	S-51 P & W R-985 (450 hp)	18	RHM38E	REM37BY REM40E	RHM38S	REM38S
Malibu PA-46-301-P Cont TSIO-520-BE (310 hp)	12	RHB32E		RHB36S RHB32S		S-55A Wright R-1300 (800 hp)	14	RHB37E	REB37E	RHB36S	REB36S
Malibu Mirage PA-46-350-P LycO TIO-540-AE2A (350 hp)	12	RHB37E RHB32E		RHB36S RHB32S		S-55C P & W R-1340 (600 hp)	18	RHM40E	REM37BY REM40E	RHM38S	REM38S
PA-60-600, 600A Aerostar 2/LycO IO-540-G1B5, K1J5 (290 hp)	12	RHM38E		RHM38S		S-56 2/P & W R-2800-50 (1800 hp)	36	RHB32E RHB37E	REB32E REB37E	RHB32S RHB36S	REB36S
PA-60-601, 601B Aerostar 2/LycO IO-540-P1A5, S1A5 (290 hp)	12	RHB37E RHB32E		RHB36S RHB32S		S-58 Wright R-1820-84 (1525 hp)	18	RHB32E		RHB32S	
PA-60-601P Aerostar 2/LycO IO-540-S1A5 (290 hp)	12	RHB37E RHB32E		RHB36S RHB32S		STINSON					
PA-60-602P Aerostar 2/LycO IO-540-AA1A5 (290 hp)	12	RHB32E RHB37E		RHB36S RHB32S		Reliant V-77 LycO R-680-13 (300 hp)	18	RHM40E	REM40E	RHM38S	REM38S
PA-60-700P 2/LycO TIO-540-UJ2A & LTIO-540-U2B (350 hp)	12	RHB37E RHB32E		RHB36S RHB32S		Vigilant V-74 LycO R-680-13 (300 hp)	18	RHM40E	REM40E	RHM38S	REM38S
REPUBLIC						Sentinel V-76 LycO O-435-1 (190 hp)	12	RHM40E	REM40E	RHM38S	REM38S
Seabee RC-3 Frank 6A8-215-B (215 hp)	12		REJ38			105 Frank 4AC-199-E2 (90 hp)	8		REJ38		
ROBINSON						Voyager 108 Frank 6A4-150 (150 hp)	12		REJ38		
R22 LycO O-320-B (160 hp)	8	RHM40E RHM38E	REM38E REM40E	RHM38S	REM38S	Voyager 108 Frank 6A4-165 (165 hp)	12		REJ38		
R22 LycO O-320-A (150 hp)	8	RHM40E	REM40E	RHM38S	REM38S	Voyager 108-5 Frank 6A335-B (180 hp)	12	RHB32E		RHB36S	
R44 LycO O-540 (205 hp)	12	RHM38E	REM38E	RHM38S	REM38S	TAYLORCRAFT					
SCHEUTZON						Deluxe BC12D Cont A-65-8 (65 hp)	8	RHM40E	REM37BY REM40E		
B LycO IVO-360-A (180 hp)	8	RHB37E		RHB36S		Sportsman 19 Cont C-85-8 (85 hp)	8	RHM40E	REM37BY REM40E		
SCHWEIZER						F19 Cont O-200-A (100 hp)	8	RHM40E	REM37BY REM40E	RHM38S	
269A LycO O-360 (180 hp) HO-360-B (180 hp)	8	RHM40E RHM38E	REM40E REM38E	RHM38S	REM38S	F21B, F22 LycO O-235-L2C (118 hp)	8	RHM40E RHM38E	REM37BY REM38E REM40E		
200 LycO HIO-360-B (180 hp)	8	RHM40E RHM38E	REM40E REM38E			Workhorse 44 Wright R-1820-103 977C9HD1	18	RHB37E	REB37E	RHB36S	REB36S
300 LycO HIO-360-A (200 hp)	8	RHM38E	REM38E	RHM38S	REM38S						
300C LycO HIO-360-DIA (190 hp)	8	RHM38E	REM38E	RHM38S	REM38S						

Most generally used plugs shown in red type. For Unshielded Spark Plugs - see pgs. 13-16. Plug Listings taken from FAA Approved Data. Please consult your aviation distributor for availability on these items.

12 Contact your preferred distributor for Champion factory FAA certified servicing of your spark plugs.

Spark Plugs



Spark Plug Application By Engine Manufacturer

Engine Model	Standard Massive Electrode Shielded		Unshielded	Fine Wire Electrode Shielded	
	5/8" - 24	3/4" - 20		5/8" - 24	3/4" - 20
ALLISON V1710	REB37E	RHB37E		REB36S	
FRANKLIN ENGINE CO.					
2A4 Series	REJ38				
2A-120-A, -B		RHB32E			RHB36S
4A4 Series	REJ38				
4AC Series	REJ38				
4A-235-B, B3		RHB32E		REB36S	RHB36S
Sport 4, 4A, 4A1, 4B, 4R		RHB32E			RHB36S
6AC, 6AL, 6AG, 6A4, 6V4 Series	REJ38				
6A4-200, 6V4-200	REL37B				
6V6-245	REL37B				
6A8-215	REJ38				
6A-335-A, B, 6V335-A, -B	REL37B			REB36S	
6AS-335-A, B, 6AS-350-A, -A1		RHB32E		REB36S	RHB36S
6V335-A1A, A1B	REB37E	RHB37E		REB36S	RHB36S
	REB37E	RHB37E			
6VS-335-A, -B	REB32E	RHB32E		REB36S	RHB36S
6A-350-C1,-C1A, -C2, -C2A, -D, -D1		RHB32E		REB36S	RHB36S
6V-350-A, -B		RHB32E		REB36S	RHB36S
GROB					
2500 D1/E1				REN30S	
GYPSY MAJOR	REL37B				
JACOBS AIRCRAFT ENGINE CO.					
L-4, L-5 & L-6 Series R-755	REM40E	RHM40E		REM38S	RHM38S
R-755S, R-755SM	REM38E				
KENROYCE-REARWIN All models	REM40E	RHM40E	M41E		
KINNER All models			M41E		
LAMBERT All models			M41E		
LEBLOND All models			M41E		
MENASCO All models except D4			M41E		
ORENDA All models					RHB27S
PRATT & WHITNEY	REM37BY*				
R-985 (Wasp Jr.), R-1340 (Wasp)	REM40E	RHM40E	M41E	REM38S	RHM38S
R-1830 (Twin Wasp C)	REB37E	RHB37E		REB36S	RHB36S
+ For Severe Service	REB32E+	RHB32E+			RHB32S+
R-2000 (Twin Wasp D)	REB37E	RHB37E		REB36S	RHB36S
R-2800 (Double Wasp) R-2800-97	REB37E	RHB37E			RHB36S
CA3, CA5, CA15, CA17, CA18, CA19	REB32E	RHB32E		REB36S	RHB32S
++ Rear position front row only		RHB29E++			
R-4360 (Wasp Major)	REB37E	RHB37E		REB36S	RHB36S
PEZETEL (WSK)					
ASZ-621R, (1000 h. p.), P2L-3S (600 h. p.)	REB37E	RHB37E		REB36S	RHB36S
RANGER All 18 mm Short Reach	REM40E	RHM40E	M41E	REM38S	RHM38S
ROLLS-ROYCE - Merlin, Griffon					RHL27S RHL28S
RUSSIAN ENGINES M14 Most Series	REL37B			RVL38S**	
TELEDYNE CONTINENTAL MOTORS	REM37BY*				
A-65, A-75	REM40E	RHM40E	M41E	REM38S	RHM38S
C75, C-85, C-90, C-115, C-125	REM37BY*				
	REM40E	RHM40E	M41E	REM38S	RHM38S
E-165, E-185, E-225	REM40E	RHM40E	M41E	REM38S	RHM38S
E-165, E-185, E-225 (14mm Bushing)	REJ38				

* Use REM37BY when encountering lead fouling. ** Uses M18x1 barrel thread instead of 5/8"-24



Spark Plugs

Spark Plug Application By Engine Manufacturer

Engine Model	Standard Massive Electrode		Unshielded	Fine Wire Electrode	
	Shielded			Shielded	
	5/8" - 24	3/4" - 20		5/8" - 24	3/4" - 20
TELEDYNE CONTINENTAL MOTORS (Cont'd)					
O-200-A, -B, -C, -D	REM37BY* REM40E	RHM40E	M41E	REM38S	RHB36S RHM38S
IO-240	REM38E	RHM38E		REM38S	RHM38S
GO-300-A, -B, -C, -D, -E, -F O-300-A, -B, -C, -D, -E, C-145	REM37BY* REM40E REM38E	RHM40E RHM38E	M41E	REM38S	RHM38S
IO-346-A, -B	REM40E REM38E	RHM40E RHM38E		REM38S	RHM38S
IO-360-A, -AB, -C, -CB, -D, -E, -G, -GB, -H, -HB, -J, -JB, -K, -KB	REM38E	RHM38E		REM38S	RHM38S
IO-360-B	REM40E	RHM40E		REM38S	RHM38S
TSIO-360-A, -AB, -B, -C, -CB, -D, -DB, -E, -EB, -F, -FB, -G, -GB, -H, -HB, -JG, -K, -KB, -LB, -MB, LTSIO-360-E, -EB, -K, -KB	REM38E	RHM38E		REM38S	RHM38S
O-470-2	REM38E	RHM38E		REM38S	RHM38S
O-470-4, -11, -13, -13A, -15	REM40E	RHM40E		REM38S	RHM38S
O-470-A, -E, -J, -K, -L, -R, -S	REM40E	RHM40E		REM38S	RHM38S
O-470-B, -G, -H, -M, -N, -P	REM40E REM38E	RHM40E RHM38E		REM38S	RHM38S
O-470-T, -U		RHB32E			RHB32S
IO-470-C, -G, -P, -R, -T	REM40E REM38E	RHM40E RHM38E		REM38S	RHM38S
IO-470-J, -K	REM40E	RHM40E		REM38S	RHM38S
IO-470-D, -E, -F, -H, -L, -M, -N, -S, -U, -V, -VO, -LO		RHB32E			RHB36S RHB32S
GIO-470-A		RHB32E			RHB36S RHB32S
LIO-470-A	REM40E REM38E	RHM40E RHM38E		REM38S	RHM38S
TSIO-470-B, -C, -D		RHB32E			RHB36S RHB32S RHB36S
IO-520-A, -B, -BA, -BB, -C, -CB, -D, -E, -F, -J, -K, -L, -M, -MB, -N, -NB		RHB32E		RHB32S	
TSIO-520-A, -B, -BB, -BE, -C, -CE, -D, -DB, -E, -EB, -F, -G, -H, -J, -JB, -K, -KB, -L, -M, -N, -NB, -P, -R, -T, -U, -UB, -V, -VB, -WB, -AE, -AF					RHB32S
LTSIO-520-AE		RHB32E			RHB36S RHB32S
GTSIO-520-C, -D, -E, -F, -G, -H, -K, -L, -M, -N		RHB32E			RHB36S RHB32S
TSIO-550-A, -B, -C,		RHB32E			RHB32S
IO-550-A, -B, -C, -D, -E, -F, -G, -L, -N, -P, -R		RHB32E			RHB36S RHB32S
TSIOL-550-A, -B		RHU32E			RHU32S
6-285-B, -BA, -C, -CA, 6-320-A, -B		RHU27E			
W-670	REM40E	RHM40E	M41E	REM38S	RHM38S
R9A	REB37E	RHB37E		REB36S	RHB36S
TEXTRON LYCOMING					
O-145, GO-145			M41E		
O-235-C, -E, -H	REM40E REM38E REM37BY*	RHM40E	M41E	REM38S	RHM38S
O-235-F, -G, -J				REM38S	
O-235-K, -L, -M, -N, -P	REM40E REM38E REM37BY*	RHM40E RHM38E		REM38S	RHM38S
O-290 Series	REM40E REM38E REM37BY*	RHM40E	M41E	REM38S	RHM38S
O-320-A, -C, -E	REM37BY*	RHM40E	M41E	REM38S	RHM38S
O-320-B, -D, -H	REM40E				
AIO-320, LIO-320-B, IO-320-B, -C, -D, AEIO-320-A, -B, -C, -D	REM38E	RHM40E			

* Use REM37BY when encountering lead fouling.

14 Contact your preferred distributor for Champion factory FAA certified servicing of your spark plugs.

Spark Plugs



Spark Plug Application By Engine Manufacturer

Engine Model	Standard Massive Electrode		Unshielded	Fine Wire Electrode	
	Shielded			Shielded	
	5/8" - 24	3/4" - 20		5/8" - 24	3/4" - 20
TEXTRON LYCOMING (Cont'd)					
IO-320-A, -B, -D, -E	REM37BY* REM40E	RHM38E		REM38S	RHM38S
AEIO-320-E	REM37BY*	RHM40E		REM38S	RHM38S
IO-320-C, -F, LIO-320-C (Long Reach)	REB37E	RHB37E		REB36S	RHB36S
O-340-A	REM40E REM38E	RHM40E RHM38E		REM38S	RHM38S
O-340-B	REM40E	RHM40E		REM38S	RHM38S
O-360-A, -C, -E, -F					
IO-360-B, -E, -F, -H, -L	REM38E	RHM40E			
AEIO-360-B, -C, -H, HO-360-A	REM37BY*	RHM38E		REM38S	RHM38S
O-360-B, -D	REM40E REM37BY*	RHM40E		REM38S	RHM38S
IO-360-A, -C, -D, -J, LIO-360-E	REM38E REM37BY*	RHM38E		REM38S	RHM38S
LO-360-A1G6D, O-360-E1A6D	REM40E				
LO-360-E1A6D	REM38E	RHM40E			
LO-360-C	REM37BY*	RHM38E		REM38S	RHM38S
IO-360-A, IO-360-C1F					
IO-360-F (Long Reach)					
IYO-360	REB37E	RHB37E		REB36S	RHB36S
AIO-360-A,	REM38E				
LIO-360-C, AEIO-360-A	REM37BY*	RHM38E		REM38S	RHM38S
HIO-360-A, -D	REM38E	RHM38E		REM38S	RHM38S
HO-360-B, HIO-360-A, -B	REM40E REM38E	RHM40E RHM38E		REM38S	RHM38S
TIO-360-A, -B, AEIO-360-A (Long Reach)	REB37E	RHB37E		REB36S	RHB36S
HIO-360-E1AD, -E1BD, -F1AD					
LHIO-360-F1AD, IYO-360-A	REB32E	RHB32E			RHB32S
TO-360-A1A6D, TO-360-C1A6D, TO-360-E		RHB37E			RHB36S
TO-360-F1A6D, LTO-360-A1A6D, LTO-360-E	REB37E	RHB32E		REB36S	RHB32S
VO-360-A, -B	REM40E REM38E	RHM40E RHM38E		REM38S	RHM38S
O-435-A, -C	REM40E REM38E	RHM40E		REM38S	RHM38S
O-435-K, K1	REM40E REM38E	RHM40E		REM38S	RHM38S
GO-435-C, -D Series	REM38E	RHM38E		REM38S	RHM38S
VO-435-A, TVO-435-A (Short Reach)	REM38E	RHM38E		REM38S	RHM38S
VO-435-A, -B (Long Reach)					
TVO-435-A, -B, -C, -D, -E, -F, -G (Long Reach)	REB37E	RHB37E			RHB36S
O-435-23-25	REB32E	RHB32E		REB36S	RHB32S
GO-480-B, -D, -F	REM40E REM38E	RHM40E RHM38E		REM38S	RHM38S
GO-480-C, -G (Short Reach)	REM38E	RHM38E		REM38S	RHM38S
GO-480-G1, G2 (Long Reach)		RHB37E			RHB36S
GSO-480-A, -B (Short Reach)	REB37E	RHB32E		REB36S	RHB32S
GSO-480-A, -B (Long Reach)	REM38E	RHM38E		REM38S	RHM38S
IGSO-480-A (Short Reach)	REB37E	RHB37E		REB36S	RHB36S
IGSO-480-A (Long Reach)	REM38E	RHM38E		REM38E	RHM38S
IGO-480-A					
O-480-1-3	REB37E REB32E	RHB37E RHB32E			RHB36S RHB32S

* Use REM37BY when encountering lead fouling.



Spark Plugs

Spark Plug Application By Engine Manufacturer

Engine Model	Standard Massive Electrode Shielded		Unshielded	Fine Wire Electrode Shielded	
	5/8" - 24	3/4" - 20		5/8" - 24	3/4" - 20
TEXTRON LYCOMING (Cont'd)	REM40E	RHM40E			
O-540-A, -D, -E, -F, -G, -H, -J, -J3A5	REM38E	RHM38E		REM38S	RHM38S
O-540-B	REM40E	RHM40E	M41E	REM38S	RHM38S
IO-540-A, -B, -E, -G, -K, -L, -M, -P, -S, -U (Short Reach)	REM38E	RHM38E		REM38S	RHM38S
IO-540-C, -D, -J, -N, -T, -V	REM40E	RHM40E			
AEIO-540-D, -L	REM38E	RHM38E		REM38S	RHM38S
IO-540-AA, -E, -G, -J, -K, -M, -P, -R, -S, -U	REB37E	RHB37E			RHB36S
O-540-L3C5D, M1B5D (Long Reach)	REB32E	RHB32E		REB36S	RHB32S
VO-540-A, -B, -C (Short Reach)	REM38E	RHM38E		REM38S	RHM38S
O-540-9					
VO-540-Series					
IVO-540 Series (Long Reach)	REB37E	RHB37E		REB36S	RHB36S
IGO-540-A, -B (Short Reach)	REM38E	RHM38E		REM38S	RHM38S
IGO-540-A, -B (Long Reach)	REB37E	RHB37E		REB36S	RHB36S
TIO-540-A, -C, -E, -F, -G, -H, -J, -K, -N, -R, -S, -T	REB37E	RHB37E			RHB36S
TIVO-540-A	REB32E	RHB32E		REB36S	RHB32S
IGSO-540-B (Short Reach)	REM38E	RHM38E		REM38S	RHM38S
IGO-540-A, -B	REB37E	RHB37E			RHB36S
IGSO-540-A, -B (Long Reach)	REB32E	RHB32E		REB36S	RHB32S
	REB37E	RHB37E			RHB36S
LTIO-540-F, -J, -N, -R	REB32E	RHB32E		REB36S	RHB32S
	REB37E	RHB37E			RHB36S
TIO-541-A, -E	REB32E	RHB32E		REB36S	RHB32S
	REB37E	RHB37E			RHB36S
TIGO-541-A, -E	REB32E	RHB32E		REB36S	RHB32S
IO-580-A		RHB37E			
R-680	REM40E	RHM40E		REM38S	RHM38S
IO-720-A, -B, -C, -D (Short Reach)	REM38E	RHM38E		REM38S	RHM38S
	REB37E	RHB37E			RHB36S
IO-720-A, -B, -C, -D (Long Reach)	REB32E	RHB32E		REB36S	RHB32S
WARNER (All Models)	REM40E	RHM40E	M41E	REM38S	RHM38S
WRIGHT AERONAUTICAL					
R-540	REM40E	RHM40E			
Whirlwind R-760, R-975 (1/2" Rch.)	REM40E	RHM40E	M41E	REM38S	RHM38S
Cyclone 9N with 1/2" insert depth (R-1820)	REM40E	RHM40E	M41E	REM38S	RHM38S
Whirlwind R-760, R-975 (18mm 13/16" Rch.)	REB37E	RHB37E		REB36S	RHB36S
Cyclone R-1300	REB37E	RHB37E		REB36S	RHB36S
Cyclone R-1820 Series (Except F & HE)	REB37E	RHB37E		REB36S	RHB36S
Cyclone R-2600 Series	REB37E	RHB37E		REB36S	RHB36S
Cyclone R-1820-84 (C9HE Series)		RHB32E			RHB32S
Cyclone R-3350, C18BA, C18BD	REB37E	RHB37E		REB36S	RHB36S
Cyclone R-3350-C18CB1		RHB29E			
Cyclone R-3350-DA1, -2, -3, -4, EA1, -2, -3		RHB29E			
Cyclone R-3350-EA4, -5, -6		RHB29E			

Additional R-3350 plugs Available for Racing Applications only - Contact Champion Aerospace LLC Regarding this Application.

Spark Plugs



Other U.S. Aircraft and Piston Aircraft

Make & Model	Engine	Plugs Per Eng.	Make & Model	Engine	Plugs Per Eng.
AERONCA			Havoc A20G	2/Wright R-2600-23	28
LA, LB	LeBlond (70 hp), (85 hp)	10	DC-2	Wright SGR-1820, F3, F52, 25	18
LC	Warner Scarab Jr. 50	10	Skytrain DC-3, C49	2/Wright R-1820-G102, G202A	18
KC	Cont A-40	8	DC-3A, C47, C53, C112	2/P & W R-1830-90, -92, -94	28
50-C	Cont A-50	8	Skymaster DC-4	4/P & W R-2000	28
50-F	Franklin 4AC-150	8	Liftmaster DC-6	4/P & W R-2800-CB16, -17	36
59-L	LycO O-145	8	DC-7	4/Wright R-3350 Compound	36
60-TF	Cont A-65	8	DOWNER		
65-LA	LycO O-145	8	14-19	LycO O-435-A	12
O-58B	Cont O-170-3 (Equiv. A65)	8	14-19-2	Cont O-470-K	12
Champion L-16B	Cont A-65-8	8	14-19-3	Cont IO-470-F	12
AIRCRAFT MFG. COMPANY			260B	Cont IO-470-F	12
Texas Bullet 205	Cont E-185-1	12	Viking 300	Cont IO-520-D	12
ALON, INC.			DOYN AIRCRAFT		
A-2	Cont C-90-16F	8	Cessna 150 Modified	LycO O-320	8
A-4	LycO O-320-A	8	Cessna 177 Modified	LycO O-360	8
ANDERSON-GREENWOOD			FLETCHER		
AG-5	Cont C-90	8	Utility FU-24	Cont O-470-E, N	12
BAUMANN			FU-24A	Cont IO-470-D	12
Brigadier B-290	Cont C-145-2	12	FU-24B	Cont GIO-470-A	12
Deluxe Brigadier B-360	2/LycO O-360	8	FORD		
Super Brigadier B-480	2/Cont O-470-B	12	4-AT-E Trimotor	3/Wright R-975	18
BEE AVIATION			5-AT-B Trimotor	3/P & W R-985	18
Honey Bee	Cont A-65	8	FORNAIRE		
Queen Bee	LycO O-320	8	Aircoupe E, G	Cont C-75, C-85	8
BOEING			Aircoupe F-1, F1A	Cont C-90	8
247D	2/P & W R-1340, R985	18	HOWARD		
Stratoliner 307B	Wright R-1820-G105A, G205A	18	DGA-8	Wright R-760-E2	14
Fortress B-17G	4/Wright R-1820-97	18	DGA-9	Jacobs L-5	14
Stearman 75, PT-17	Cont W-670	14	DGA-11	P & W R-985	18
Stearman 75, PT-13	LycO R-680	18	DGA-12	Jacobs L-6	14
Stearman 75 (Modified)	P & W R-985	18	DGA-15P	P & W R-985-AN-12	18
Stratocruiser B377	4/P & W R-4360	56	HOWARD AERO		
CAMAIR			Super Ventura 237		
480	2/Cont O-470-B	12	(Converted)	2/P & W R-2800-CB	36
CENTRAL-LAMSON			LANE AIRCRAFT		
Air Tractor L-101	P & W R-985	18	Riviera	Cont IO-470-P	12
CONVAIR			LARK AVIATION		
Liberator C-87	4/P & W R-1830-43	28	Lark 95	Cont C-90	8
Catalina PBY-5A	2/P & W R-1830-92	28	LEAR		
(Modified Version)	2/Wright R-2600-29	28	Learstar	2/Wright R-1820, C-9HD	18
240, 340, 440	2/P & W R-2800 C Series	36	LOCKHEED		
CULVER (Superior)			Electra 10, 10A	2/P & W R-985-SB2	18
Cadet LCA	Cont A-75	8	Electra 10B	2/Wright R-975-E3	18
V	Cont C-85	8	Electra 10C	2/P & W R-1340, S3H-1	18
CURTISS-WRIGHT			Electra 12A	2/P & W R-985-SB2	18
Falcon CW-22, SNC-1	Wright R-975-E3	18	Super Electra 14-H-2	2/P & W R-1690	18
Commando C-46	2/P & W R-2800-51, -75, -79	36	Super Electra 14-F62	2/Wright GR-1820, -F62	18
(Modified Version)	2/P & W R-2800-CB16	36	Super Electra 14-G3B	2/Wright GR-1820, -G3B	18
Satellite	Cont C-90	8	Lodestar 18-56	2/Wright R-1820, G-202A, G205A	18
LFA	Franklin 4AC-176-D2	8	Lodestar 18-08	2/P & W R-1830-92, S1C3G	28
DAVIS AIRCRAFT			Hudson 414	2/Wright R-1820, G205A	18
DA-1	LycO O-360-A1A	8	Ventura 237	2/P & W R-2800, S1A4G	36
DOUGLAS			Constellation 049	4/Wright R-3350, -BA3	36
Bolo B-18A	2/Wright R-1820	18	Constellation 649, 749	4/Wright R-3350, BD1	36
Dragon B-23	2/Wright R-2600-29	28	Constellation 1049	4/Wright R-3350, CB1	36
Invader B-26	2/P & W R-2800-27	36	Super Constellation 1049C,G,H	4/Wright R-3350-DA	36
Dolphin D-117	W R-985	18	Starliner 1649	4/Wright R-3350-EA	36
			402-2	Cont IO-470-R, TSIO-470-B	12



Spark Plugs

Other U.S. Aircraft and Piston Engines

Make & Model	Engine	Plugs Per Eng.	Make & Model	Engine	Plugs Per Eng.
MARTIN			SPACE ENTERPRISES		
202, 404	2/P & W R-2800-CA, -CB	36	Spacecoupe AG-14	Cont C-90	8
Marauder B26	2/P & W R-2800-83AM8	36	SPARTON		
MONOCOUCPE			Executive 7-W	P & W R-985	18
90A	Warner Scarab 125 & 145	14	STITS		
90AF	Franklin 4AC-199-E3	8	Skycoupe SA9A	Cont C-90-12F	8
90AL-115	LycO O-235-C	8	Skycoupe SA9B	Cont O-200-A	8
90AL-125	LycO O-290-A	8	TEMCO		
Meteor 2	2/LycO O-320	8	Swift GC-1A	Cont C-85	8
MORRISEY (Shinn)			Swift GC-1B	Cont C-125	12
2000C	Cont C-90-14F	8	Swift GC-1B (Modified)	Cont C-145	12
2150	LycO O-320-A2A	8	Swift GC-1B (Modified)	LycO O-320-A	8
NAVAL AIRCRAFT FACTORY			TRANSLAND		
N3N-3	Wright R-760-8	14	AG-2	P & W R-985, R-1340	18
N3N-3 (Modified)	P & W R-985	18	TRECKER		
NORTH AMERICAN			Royal Gull L-1	2/LycO GO-480-B1B	12
Mitchell B-25	2/Wright R-2600-29	28	Super Gull L-2	2/LycO GSO-480-A1A6	12
Texan T-6	P & W R-1340-AN1	18	VARGA		
T28A	Wright R-1300	14	Kachina 2150A	LycO O-320-A	8
OAKLAND AIRMOTIVE (Fleet)			VECTO MFG.		
Super V	2/LycO. O-360-A1A	8	Geronimo	2/LycO O-360-A1A	8
OLSON AIRCRAFT			VULTEE		
Ambassador	Cont O-200-A	8	Valiant 54, BT-13, SNV	P & W R-985-AN1	18
ON MARK ENGINEERING CO.			WACO		
Marksman B26K	2/P & W R-2800	36	ZVN-7	Jacobs L-5	14
RILEY & TEMCO			ZVN-8	Jacobs L-6	14
Twin Navion	2/LycO O-320-A2A	8	YMF-5	Jacobs R755B2	14
Riley Navion	2/LycO O-340-A1A	8	WACO AIRCRAFT DIVISION		
Temco Model 58	2/GSO-480-A1A6	12	S-220 Vela		
310R	2/Cont IO-470-D	12	Frank 6A-350-C1		12
Riley Rocket	2/LycO IO-540-A1A5	12	TS-250-5 Vega	Frank 6A-350	12
Turbo Executive 400 (Converted DeHaviland Dove)	2/LycO IO-720-A	16	M220-4 Minerva	Frank 6A-350-C1	12
Turbo Skyliner (Converted Heron)	4/LycO IO-540	12	SF-260-3 Meteor Mk. I	LycO O-540-E	
ROBERTSON AIRCRAFT			TS-250-3F Meteor Mk. II	Frank 6A-350-C1	12
Cessna 180 Modified	Cont. TSIO-520-C	12	WEATHERLY AVIATION		
SNOW AERONAUTICAL			Model 201A	P & W R-985	18
S-2A	Cont W-670, Jacobs R-755	14	WINDECKER RESEARCH		
S-2B	P & W R-985, R-1340	18	Eagle I	Cont IO-520	12
			WING AIRCRAFT		
			Derringer	2/LycO IO-320-B	8
			WREN AIRCRAFT		
			Wren 460	Cont O-470-R	12

U.S. Helicopter and Piston Engines

Make & Model	Engine	Plugs Per Eng.	Make & Model	Engine	Plugs Per Eng.
BELL			DOMAN		
Utility 47G	Frank 6V4-200-C32	12	LZ-5-1, -2	LycO SO-580-A1B	16
Utility 47G-2	LycO VO-435-A1B	12	D-11	LycO SO-580-A1B	16
Utility 47G-3B	LycO TVO-435A	12	ENSTROM		
Utility 47G-3B1, 47G-3B2	LycO TVO-435-B1A	12	F28A, C, F280C,	LycO HIO-360-E	8
Utility 47G-3	Frank 6VS-335	12	F28BF, 28F, 280F,	LycO TIO-360-B2A	8
Utility 47G-4, 47G-4A	LycO VO-540-B1B3	12	Shark, 280FX, 280L	LycO HIO-360-F1AD	8
Bellarus 47H, 47H-1	Frank 6V4-200-C32	12	HILLER		
Ranger 47J, 47G-5, 47G-5A	LycO VO-435-A1B, B1A	12	UH-12B	Frank 6V4-200-C33	12
Ranger 47J2	LycO VO-540-B	12	UH-12C	Frank 6V-335-B	12
BRANTLY			UH-12D	LycO VO-435-A1C	12
B-2	LycO VO-360-A1A	8	UH-12E, 12E4	LycO VO-540-C2A	12
B-2	LycO HO-360-B1B	8	UH-12L	LycO VO-540-C	12
B2B	LycO IVO-360	8	SL 3/4	LycO TIVO-540-A	12
305	LycO VO-540-B	12			
305A	LycO IVO-540-A1A	12			

18 Contact your preferred distributor for Champion factory FAA certified servicing of your spark plugs.

Spark Plugs



U.S. Helicopter and Piston Engines

Make & Model	Engine	Plugs Per Eng.	Make & Model	Engine	Plugs Per Eng.
HYNES			SCHWEIZER		
H-2	Lyco IVO-360-A1A	8	200	Lyco HIO-360-B	8
H-5	Lyco IVO-540-A1A	8	269-A	Lyco O-360-C2B	8
JOVAIR CORP.			300	Lyco HIO-360-A	8
4E Sedan	Frank 6V-335	12	300-C	Lyco HIO-360-D1A	8
KAMAN			SIKORSKY		
K-240	Lyco O-435-4	12	S-51	P & W R-985-B4	18
OMEGA			S-55A	Wright R-1300-3	14
BS-12SR/BS-12SC	2/Frank 6A-335-A	12	S-55C	P & W R-1340-57	18
BS-12A	2/Lyco O-540-F	12	S-56	2/P & W R-2800-50	36
ROBINSON			S-58	Wright R-1820-84	18
R22 Alpha	Lyco O-320-B2C	8	VERTOL		
SCHEUTZON			Workhorse 44	Wright R-1820-103-977C9HD1	18
Model B	Lyco IVO-360-A	8			

International Aircraft Using U.S. Piston Engines

Make & Model	Engine	Plugs Per Eng.	Make & Model	Engine	Plugs Per Eng.
ARGENTINA AERO BOREO			EMBRAER		
Model 95	Cont C-90-12F	8	Corisco EMB-711ST	Cont TSIO-360-FB1	12
Model 115	Lyco O-235-C2A	8	Ipanema EMB-200	Lyco O-540-H2B5D	12
Model 150	Lyco O-320	8	Ipanema EMB-200A	Lyco O-540-H1B5D	12
Model 180	Lyco O-360-A	8	Ipanema EMB-201	Lyco O-540-K1J5D	12
Model 260	Lyco O-540	12	Minuano EMB-720D	Lyco IO-540-K1G5	12
AVIONES LOCKHEED-KAISER			Seneca EMB-810D	Cont L/TSIO-360	12
CL-402	Cont IO-470-R & TSIO -470	12	Sertanejo EMB-721	Lyco IO-540-K1G5D	12
I.A.E.			Tupi EMB-712	Lyco O-360-A4M	8
Calquin 24	2/P & W R-1830-SC-G	28	FABRICA DO GALLEAO		
Model 45	2/Lyco O-320-A	8	Niess Maranhao	Cont C-85	8
Model 46 Ranquel	Lyco O-320-A	8	FOKKER		
Model IA-46 180 Ranquel	Lyco O-360-A1A	8	S-11	Lyco O-435	12
PETROLINI			NEIVA		
El Boyero	Cont A-65	8	IPD 5802	Lyco O-320-A	8
AUSTRALIA			Paulistinha	Frank 4AC-176-B2	8
COMMONWEALTH			Paulistinha 56	Cont C-90-8F	8
Ceres CA-28	P & W R-1340, S3H1	18	Regente	Lyco O-360-A	8
Transavia	PL 12/T-300 & PL 12/T-400	12	Universal T-25	Lyco IO-540-K1D5	12
Wackett	Warner Super Scarab	14	OMAREAL		
Winjeel CA-25	P & W R-985-SB3	18	Casmuniz 52	2/Cont E-185-11	12
Wirraway 3	P & W R-1340, S1H1	18	CANADA		
DE HAVILLAND			AVRO (Federal)		
Drover DHA-3	3/Lyco O-360-A	8	Anson 5	P & W R-985-AN-12B	18
VICTA AVIATION LTD.			C.C.F.		
Airtourer 100	Cont O-200-A	8	Norsman V	P & W R-1340, S3H1	18
Airtourer 115	Lyco O-235-C1	8	CANADAIR		
YOEMAN AVIATION			CL215	2/P & W R-2800-CA-3	36
YA-1 Cropmaster	Lyco 540-A1A5	12	DE HAVILLAND		
AUSTRIA			Beaver DHC-2	P & W R-985	18
GRAZ-PAUKER			Otter DHC-3	P & W R-1340, S3H1	18
Flamingo M-222	2/Lyco O-320-A	8	Caribou DHC-4	2/P & W R-2000-D5	28
Flamingo SPG222	2/Lyco IO-360	8	FAIRCHILD		
BELGIUM			Husky F11	P & W R-985-SB3	18
AVIONS FAIREY			FLEET		
Typsy Junior	Cont A-65	8	Canuch 80	Cont C-85-12J	8
BRAZIL			FOUND BROS. AVIATION		
AEROTEC			FBA-2A, FBA-2C	Lyco O-540-A1D	12
Uirapuru T-23	Lyco O-320-B2B	8	100 Centennial	Lyco IO-540-G	12
			NORTHWEST INDUSTRIES		
			Ranger	Lyco IO-720-A	16



Spark Plugs

International Aircraft Using U.S. Piston Engines

Make & Model	Engine	Plugs Per Eng.	Make & Model	Engine	Plugs Per Eng.
CHILE			JODEL		
FANAERO			D-112	Cont A-65	8
Chincol	Cont O-470-11	12	D-120	Cont C-90	8
CHINA, REPUBLIC OF (Taiwan)			D-140	Lyco O-360	8
A.I.D.C.			JURCA		
PL1B	Lyco O-320-E2A	8	M.J. 2 Tempete	Cont A-65	8
CZECHOSLOVAKIA ZLIN			LATECOERE		
50LS	Lyco AEIO-540-L1B5D	12	631	6/Wright R-2600-20	28
EGYPT			LEGRAND-SIMON		
HELIOPOLIS AIRWORKS			LS-50	Cont C-90	8
Gomhouria MK-2	Cont C-145	12	MATRA AIRCRAFT		
MK-6	Cont O-300	12	Magnet Jupiter	2/Lyco IO-360-A	12
FINLAND			MAX HOLSTE		
HEINONEN			Broussard M.H. 1521	P & W R-985	18
HK-1	Cont A-65	8	Super Broussard MH-250	2/P & W R-1340	18
VALMET			Major Broussard MH-350	2/Cont GIO-470-A	12
L-70	Lyco AEIO-360-A1B6	8	MORANE-SAULNIER		
PIK-11	Cont A-65-8	8	RALLYE		
PIK-23	Lyco O-360-A4M	8	MS-880	Cont C-90, O-200	8
Tuuli TL-111	Cont O-470-A	12	MS-885	Lyco O-320-A	8
FRANCE			MS-890	Lyco O-360	8
ADAM			MS-893	Lyco IO-360	8
Loisers R.A. 14	Cont A-65-8	8	PIEL		
Major R.A. 15	Cont C-75	8	Emeraude C.P. 301	Cont C-90-12F	8
SOCATA			POTEZ-SEEMS		
TB9 Tampico	Lyco O-320-D2A	8	MS-885 Super Rallye	Cont O-300	12
TB10 Tobago	Lyco O-360-A1AD	8	REIMS AVIATION		
TB20 Trinidad	Lyco IO-540-C4D5D	12	F150, FA150	Cont O-200-A	8
TB21 Trinidad TC	Lyco TIO-540-ABIAD	12	FRA150L, M	RR/Cont O-240	8
TB30	Lyco AEIO-540-L1B5D	12	F172D thru K	RR/Cont O-300-A	12
AUBERT			F172L, M	Lyco O-320-E	8
Cigale PA-204L	Lyco O-320	8	FR172 Rocket	RR/Cont IO-360-D	12
Super Cigale	Lyco O-360	8	F177RG Cardinal	Lyco IO-360-A	8
AVIONS PIERRE ROBIN			A182J thru N	Cont O-470-R	12
Dauphin	Lyco O-235-L2A	8	F337	2/RR/Cont IO-360-C & D	12
Major	Lyco O-320-D2A	8	FT337 Super Skymaster	2/Cont TSIO-360-C	12
Regent, Remorqueur	Lyco O-360-A3A	8	ROBIN (CEA)		
8R2160, R3000	Lyco O-320-D2A	8	2 + 2 Tricycle	Lyco O-235-C	8
BOISAVIA			Cadet, Petit Prince	Lyco O-235-C	8
Mercury B-601	Lyco O-435-1	12	Chevalier	Lyco O-320-D	8
(<i>Equiv. O-435-K, -K1</i>)	Cont E-165-4	12	Major 160	Lyco O-320-E	8
Mercury B-602, B-60	Lyco O-320	8	Prince	Lyco O-360-D	8
BREQUET			Regent	Lyco O-360-A	8
Provence 763	4/P & W R-2800-CA18	36	HR-100	Lyco IO-360	8
BROCHET			HR-100	Lyco O-540-B	12
M.B. 120	Cont C-90	8	HR-100	Cont 6A-285	12
C.A.B.			SCINTEX		
Minicab GY-20	Cont A-65-8	8	ML .250 Rubis	Lyco O-540-A	12
Supercab GY-30	Cont C-90	8	SIPA		
CENTRE-EST			S-91	Cont C-85-12F	8
DR-100	Cont C-90	8	S-94	Cont C-90-8-F	8
Ambassadeur DR-1050	Cont O-200	8	Coccinelle S-1000	Cont C-90-12F	8
DRUINE			S-1100	2/P & W R-1340	18
Condor DO-61	Cont A-65	8	S.N.C.A.N		
Condor DO-62	Cont C-90	8	Nord 2503	2/P & W R-2800-CB17	36
GARDAN			SOCATA		
Horizon GY-80	Lyco O-320-A	8	Gabier R235F	Lyco O-540-B4B5	12
HUREL-DUBIOS			Diplomate, Provence ST-10	Lyco IO-360-C	8
H.D. 34, 321	2/Wright R-1820	18	Rallye Club	RR/Cont O-200-A	8
			Rallye Minerva	Franklin 6A-350-C1	12
			Rallye Commodore	Lyco O-360-A	8
			Rallye 7	Lyco IO-540-K	12
			Tampico TB9	Lyco O-320-D2A	8
			Tobago TB10	Lyco O-360-A1AD	8
			Trinidad TB20	Lyco IO-540-C4D5D	12
			Trinidad TB21	Lyco TIO-540-AB1AD	12

20 Contact your preferred distributor for Champion factory FAA certified servicing of your spark plugs.

Spark Plugs



International Aircraft Using U.S. Piston Engines

Make & Model	Engine	Plugs Per Eng.	Make & Model	Engine	Plugs Per Eng.
FRANCE (Cont'd)			BRITTEN-NORMAN		
SUD-EST			BN-2B-21 Islander		
Languedoc S.E. 161	4/P & W R-1830-92	28	BN-2 Islander	2/Lyco O-540-E	12
Bretagne S.O. 30P	2/P & W R-2800-CA18	36	BN-2A-2 Islander	2/Lyco IO-540	12
WASSMER			BN-2A Trislander	3/Lyco O-540-E	12
D-120	Cont C-90	8	BROOKLANDS		
Super 4 Sancy	Lyco O-360-A	8	DA-7 Optica Scout		
Super 4/21-235	Lyco O-540-B2B	12	Lyco IO-540		12
Super 4/21-250	Lyco O-540-A	12	NORMAN		
Super 4 Baladou WA-41	Lyco O-360-A	8	NAC-1 Freelance		
Super 4 Sancy WA-40A	Lyco O-360-A	8	Lyco O-360		8
Pacific WA51	Lyco O-320-E	8	PERCIVAL		
GERMANY			E.P. 9		
BOELKOW/MBB			Prospector		
BO-207	Lyco O-360-A1A	8	SCOTTISH-AVIATION		
BO-208 A/C	Cont O-200-A	8	Twin Pioneer		
BO-209	Lyco 320-E2F	8	2/P & W R-1340		18
BO-209C	Cont O-240-A	8	SHORT		
BUECKER			Sandringham		
BU-181B1	Lyco O-235-C	8	4/P & W R-1830-90C		28
131 Lerche	Lyco IO-360-B1B	8	INDIA		
DORNIER			HINDUSTAN		
DO-27A, -27B-2/3, -27Q-1/4/5	Lyco GO-480-B1A6	12	Basant HA-31		
DO-27B-1	Lyco IO-540-A1D	12	Pushpak		
DO-27H-2	Lyco GSO-480-B1A6	12	Lyco IO-720-C		16
DO-28A-1	Lyco O-540-A1D	12	Cont C-90		8
DO-28B-1	Lyco IO-540-A1A5	12	INDONESIA		
DO-28D-1/D-2	Lyco IGSO-540-A1E	12	ANGKATAN		
EQUATOR AIRCRAFT GMBH			NU-85 Grasshopper		
P-300, 350	Lyco TIO-540	12	NU-225 Sikumbag		
P-400	Lyco IO-720	16	ITALY		
P-420	2/Lyco TO-360	8	AGUSTA		
P-450	Lyco TIGO-540	12	P.111 (Equiv. O-435-K, -K1)		
GROB			47G		
G115 / G115A	Lyco O-235-H2	8	47G-2, 47J		
G115B	Lyco O-320-D1A, -D2A, -D3G	8	Model 102		
G115C	Lyco O-320-DIA	8	ALAPARMA		
G115C2	Lyco O-360-A1F6	8	Montelli AM-10		
G115D	Lyco AEIO-360-B1F	8	Cont A-65		8
G115D2	Lyco AEIO-320-D1B	8	AMBROSINI		
G115T	Lyco AEIO-540-D4A5	12	Rondone		
KLEMM			Rondone		
KL 107 B/C	Lyco O-320-A2A	8	Lyco O-290-D2		
RHEIN-FLUGZEUGBAU GMBH			AVIMILANO		
X114	Lyco IO-360	8	Falco F-8		
SCHEIBE			Falco F-8L		
SF 23/A/A1/B	Cont C-90-12F	8	Nibbio F-14		
SF 23-C	Lyco O-235-C1	8	Scricciolo P-19		
SPORTAVIA-PUETZER			Cont C-90-12F		
Elster B	Cont C-90-12F	8	FIAT		
Elster C	Lyco O-320-A2B	8	G-49-2		
GREAT BRITAIN			P & W R-1340		
BEAGLE-AUSTER			LUALDI		
Atlantic	Cont E-185	12	L-55		
Alpha J5 & 5A	Lyco O-290	8	MACCHI		
Arrow J/2	Cont C-75-12	8	M.B. 308		
Agricola B-8	Cont O-470-M	12	Cont C-85, C-90		
Pup 150	Lyco IO-320	8	2/Cont E-185, E-225		
Workmaster, Airdale A109	Lyco O-360-A	8	P & W R-1340		
B121	RR/Cont O-200	8	Cont TSIO-470-B		
B206S	2/RR/Cont GTSIO-520-C	12	METEOR		
BEAGLE-MILES			F.L. 3		
Caravan HDM-106	2/Lyco GSO-480-B	12	F.L. 53		
Martlet M 117	Cont O-200	8	F.L. 54		
			F.L. 55		



Spark Plugs

International Aircraft Using U.S. Piston Engines

Make & Model	Engine	Plugs Per Eng.	Make & Model	Engine	Plugs Per Eng.
ITALY (Cont'd)			VEST AIRCRAFT		
NARDI			Super Heron (Modified)	4/Lyco GSO-480-B1A6	12
FN-333	Cont O-470-H	12	NETHERLANDS		
PARTENAVIA			HOLLANDAIR		
P48B	Cont A-65	8	H. A. -001 Libel	Lyco O-290-D2	8
P52	Cont C-90	8	PHILIPPINE REPUBLIC		
P59	Cont O-200	8	BUREAU OF SCIENCE		
P55, P57	Lyco O-320	8	L-21S Vinta	Cont O-470-B	12
P57-1	Lyco O-340	8	POLAND		
P57-11	Lyco O-360-B	8	L.W.D.		
P64B Oscar 180	Lyco O-360-A	8	ZAK-2	Cont A-65	8
P64B Oscar 200	Lyco IO-360-A	8	Polskie Zaklady	Cont TSIO-360	12
P66B Oscar 100	Lyco O-235-C	8	PzL-M20	Cont TSIO-360-KB	12
KANPUR			SPAIN		
HA-31 Mk.2	Lyco IO-720-C1B	16	AISA		
PIAGGIO			Peque I-11B	Cont C-90-12F	8
P66B Oscar 150	Lyco O-320-A	8	AVD-12C	Cont O-470-A	12
P66C	Lyco O-320	8	C.A.S.A		
P68, P68B, P68C, P68R	2/Lyco IO-360-A	8	Halcon CASA 202B	2/Wright R-1820-56	18
P68TC	Lyco TO-360-C	8	DORNIER		
P70 Alpha	RR/Cont O-200-A	8	C-127A	Lyco GO-480-B	12
	Lyco GO-435-C2	12	HISPANO		
P-149	GSO-480-B1A6	12	HA-100-F1	Wright R-1300	14
P-136	2/Frank 6A8-215-B9F	12	SCOTLAND		
P-136-L	2/Lyco GO-435-C2	12	SCOTTISH AVIATION		
P-136-L1	2/Lyco GO-480-B	12	Bullfinch	Lyco AEIO-360-A	8
P-136-L2	2/Lyco GSO-480-A1A	12	SWEDEN		
P-148	2/Lyco O-435-A	12	ANDEREAASSON		
P-166	2/Lyco GSO-480-A1A	12	BA-6	Cont A-65, C-85	8
P-155-SAM-1	2/P & W R-2800	36	GOTAVERKEN		
P-150	P & W R-1340	18	GV-38	LeBlond (90 hp)	10
P-166-B/C	Lyco IGSO-540	12	A.B. MALMO		
PROCAER PICCHIO			MFI Junior	Cont O-200	8
F-15	Lyco O-320-B	8	MFI-10 Vipan	Lyco O-320-A	8
F-15A	Lyco O-360-A	8	MFI-10C Vipan	Lyco O-360	8
SIAI-MARCHETTI			SAAB		
Riviera	Cont IO-470-P	12	90-A-2	2/P & W R-1820	28
S206	Franklin 6A-350-C1	12	91-B, -C Safir	Lyco O-435-A	12
S-205-18R	Lyco O-360-A	8	91-D	Lyco O-360-A1A	8
S-205-20/F, 205-20/R	Lyco IO-360-A	8	Safari	Lyco IO-360	8
S-205-22R	Franklin 6A-350-C1	12	SWITZERLAND		
S-208, SF-260, F-260, F-260B	Lyco O-540-E	12	FFA FLUG-UND		
S-F260C	Lyco AEIO-540-D4A5	12	FAHRZEUGWERKE		
JAPAN			AS 202/15	Lyco O-320-E2A	8
FUJI			AS 202/18A	Lyco AEIO-360	8
Nikko LM-1, Mentor B-45	Cont O-470-13	12	AS202/26A	Lyco AEIO-540-D4B5	12
KM-11	Lyco GSO-480-A1A	12	PILATUS		
Aero-Subaru	Lyco O-320-B	8	P-3	Lyco GO-435-C2A	12
FA-200-160	Lyco O-320-D	8	PC-6	Lyco GSO-480-B1A6	12
FA-200-180	Lyco O-360-B	8	YUGOSLAVIA		
TL-1	Lyco IGSO-480-A1A6	12	IKARUS		
T3	Lyco IGSO-480	12	Type 214, 522	P & W R-1340	18
KAWASAKI			UTVA AIRCRAFT FACTORY		
KAL-1, -2, KAT-1	Lyco GO-435-C2B	12	UTVA-75, -75V	Lyco IGO-360-B1F	8
TACHIKAWA			UTVA Lasta	Lyco AEIO-540	12
R-HM	Cont C-90	8			
MEXICO					
AZCARATE					
LA-60	Cont IO-470-R	12			
	Cont TSIO-470-A	12			

22 Contact your preferred distributor for Champion factory FAA certified servicing of your spark plugs.

SLICK by Champion



SLICK by Champion

A graphic advertisement for Slick by Champion. The background is split into a light gray upper half with a grid pattern and a dark gray lower half. On the left, a black lightning bolt icon is inside a white circle with the word "SLICK" below it. On the right, a globe contains the "CHAMPION AEROSPACE" logo. Below the globe is the tagline "Bringing Power to Flight®". At the bottom center, the word "SLICK" is written in large, bold, white letters, with "by CHAMPION®" in smaller white letters on a black oval background below it.

Consult Slick by Champion L-1318 for complete application. Available free at www.championaerospacepubs.com



SLICK by Champion



Slick. Really, Slick.

One Powerful Kit • One Proven Source • Total Energy Delivered



Trust is earned

SLICK
by CHAMPION

Announcing a complete piston ignition system from the leader in aviation
Champion spark plugs Slick by Champion™ harnesses and magnetos

Consult Slick by Champion L-1318 for complete application. Available free at www.championaerospacepubs.com



*Soaring to
new heights
with innovative
performance
technology
solutions*

Slick Harnesses by Champion



Consult Slick by Champion L-1318 for complete application. Available free at www.championaerospacepubs.com



SLICK by Champion



"World record flights are nerve-wracking enough without having to worry about starting on time. All 28 records we hold with the Exxon Flyin' Tiger have started with SlickSTART."
- BRUCE BOHANNON

Cold start. Hot start. Any start. **SlickSTART™**

Also From Champion...

LASAR



Slick Magnetos



Champion Aviation Spark Plugs



Slick Harnesses



Improve your engine starting — hot or cold. SlickSTART™ unleashes a firestorm of ignition energy to get your engine started and get you off the ground. SlickSTART is so effective, even sub-optimal fuel mixtures and seriously fouled plugs won't stop the capacitive discharge output from providing the ignition boost your engine needs for reliable starts every time.

SlickSTART's sure starting power...

- Delivers up to 340% more spark energy to your plugs.
- Overcomes poor engine priming.
- Reduces costly electrical stress to your battery and starter.
- Requires no maintenance.
- Is approved for use with Slick magnetos.

Plus, it's inexpensive and easy to install. Just add SlickSTART to your impulse coupled magnetos or replace your antiquated starting vibrator.

For more information, call Champion Aerospace today.



Champion Aerospace LLC
1230 Old Norris Road
Liberty, South Carolina U.S.A. 29657
Email: slicksupport@champaero.com
www.championaerospace.com
© 2009 Champion Aerospace LLC

Slick and LASAR® are registered trademarks of Champion Aerospace LLC

Consult Slick by Champion \$L2-96 for complete application. Available free at www.championaerospacepubs.com

4300/6300 Series Magneto

Now
Open for inspection

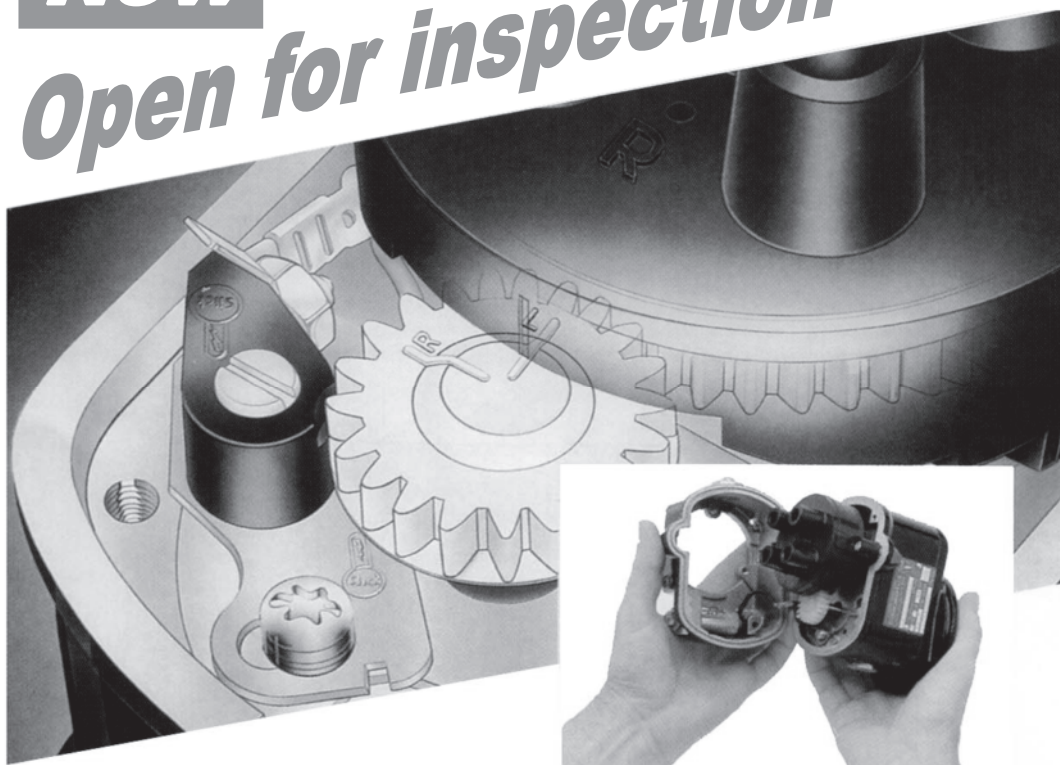

Take a close look at Slick's 4300/6300 Series and you'll see what we are doing to make magnetos better.

At Champion Aerospace, we're always looking for ways to make our magnetos better. So we asked experienced mechanics for their ideas on the ideal magneto.

The result is Slick 4300/6300 Series magnetos that make timing, installation, inspection, and maintenance simpler and more convenient than ever before. We also incorporated mechanic-endorsed features to improve performance and service life.

- **Lift-off housing** – Internal timing is not disturbed during inspections.
- **Simplified internal timing** – Improved internal markings and unique Slick E-gap tool make timing easier and more accurate.
- **Fully sealed bearings** – Keeps contaminants out and grease in for smoother operation, less maintenance.
- **Lower EMI Levels** – Redesigned housing improves sealing and results in less radio noise.
- **OEM Approved** – Models are available for more than 225,000 engines – all compatible with existing Slick Ignition Harnesses.

Get the ignition system that meets your needs for simple maintenance and quality performance. Contact your Slick Distributor for application information.



SLICK by Champion

Aircraft Engine Applications

Cold start. Hot start. Every start.

SlickSTART™

SlickSTART™ is so effective, even sub-optimal fuel mixtures and seriously fouled plugs won't stop the capacitive discharge output from providing the ignition boost your engine needs for reliable starts every time. It's inexpensive, easy to install and requires no maintenance! If you want to deliver up to 340% more spark energy to your plugs, overcome poor engine priming and reduce electrical stress to your battery and starter, then SlickSTART is the answer for you!

For more information, call or log onto www.championaerospace.com.



Trust is earned

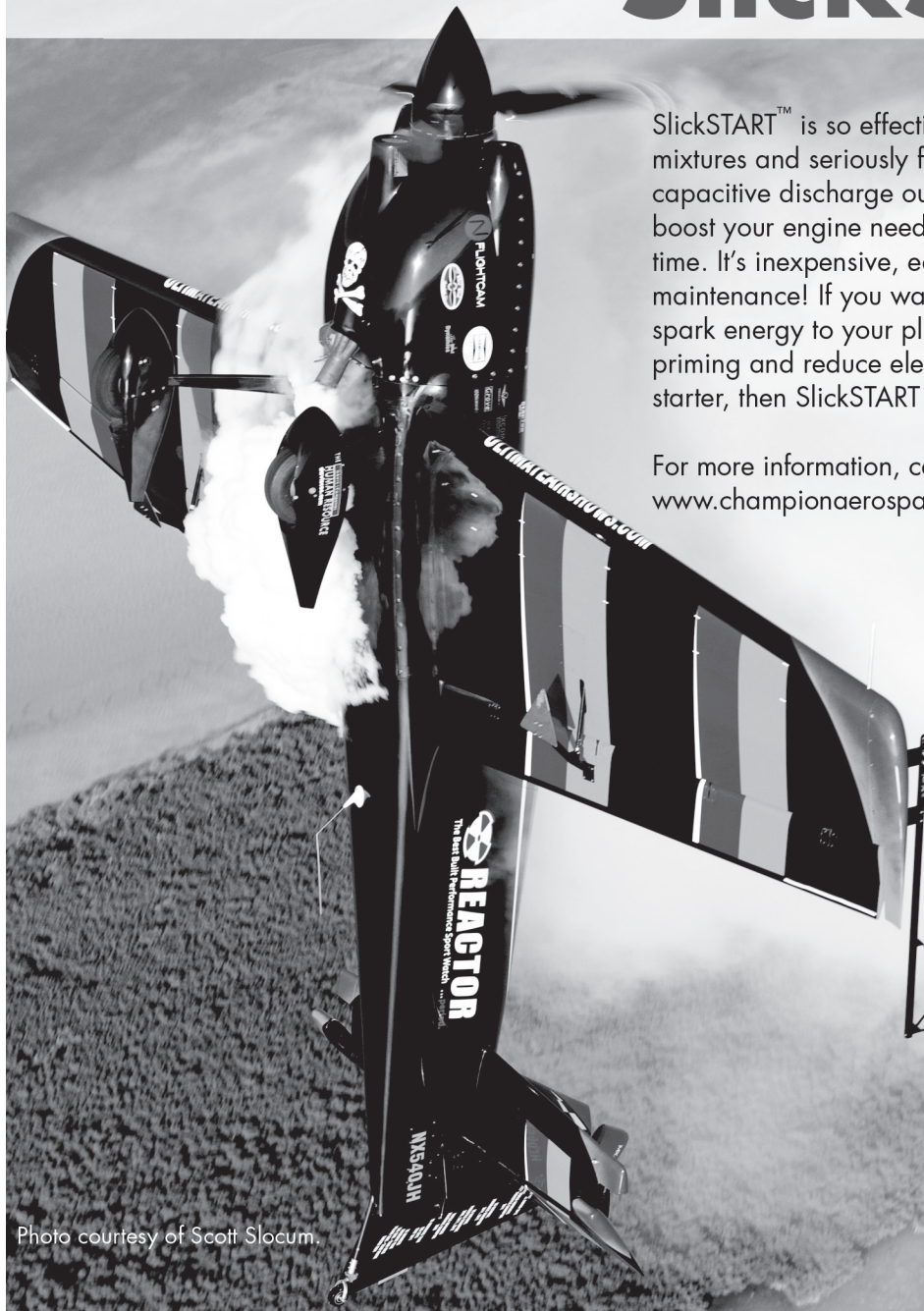

Photo courtesy of Scott Slocum.

Consult Slick by Champion L-1318 for complete application. Available free at www.championaerospacepubs.com

Introducing a New, Improved Shorter Oil Filter

Customers told us the height of a standard oil filter can make it difficult for them to install the filter in certain engine applications. So, operating on the premise that size really does matter, we made our Champion oil filter can 1/2" shorter and, in the process, added design improvements that now make our filters stronger and more effective than ever before.

By-Pass Valve

Meets TCM Specifications

Shorter Installed Height

Shortened can height by approximately 1/2", with no impact to the filter media's performance.

Improved Spring

Replaced old "leaf" spring with an improved coil spring design.

Thicker-Walled Can

Increased wall thickness for improved structural integrity.

Stronger Center Tube

Redesigned center tube for added strength, with collapse pressures more than double the current design.

New Inlet Design

Changed four-hole design to an eight-hole design for approximately 30% greater inlet flow area.

Increased Lid Thickness

Increased thickness of seaming lid by approximately 35%, which subsequently provided for higher burst and impulse testing.

Improved Baseplate Thread

Replaced cut thread with an improved rolled thread, without affecting tolerances on the thread dimensions.

New Zinc-Plated Stud

Incorporated new zinc-plated stud for increased protection against rust and corrosion (applicable to Champion part numbers CH48110-1 and CH48111-1).

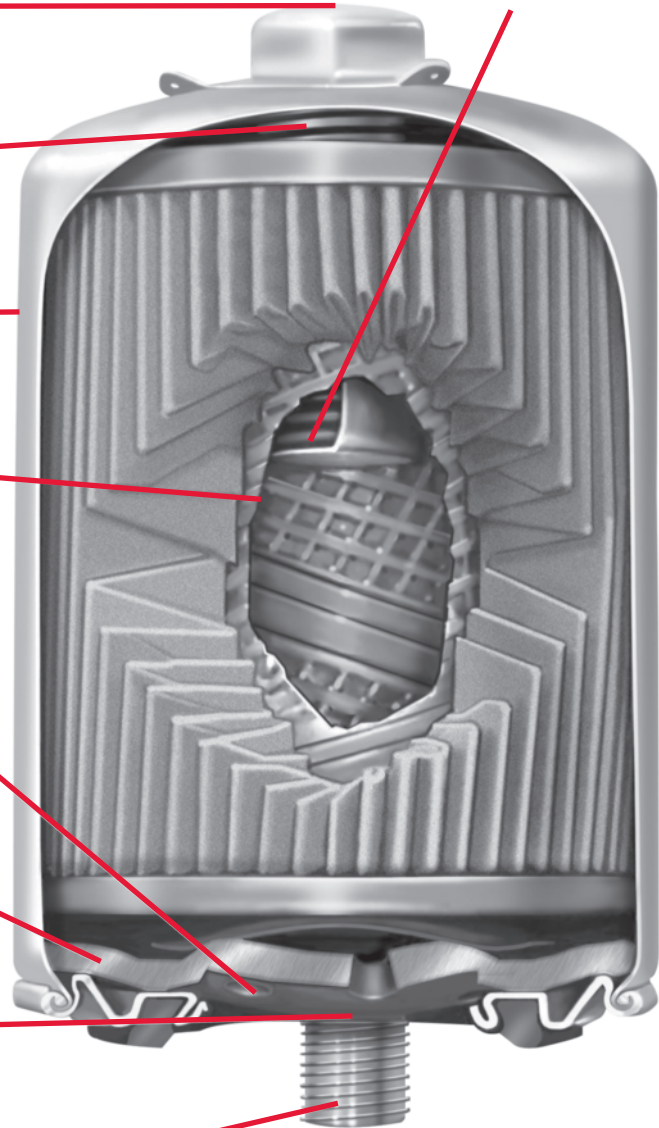

Oil Filters

See what a sizeable difference 1/2" can make in your life. For more information, call, fax, or log onto www.championaerospace.com



Champion Aerospace's full-pleat, resin-impregnated micronic filter media traps all harmful particles, including metallic chips which result from abnormal engine wear. Because the oil flows through many layers of locked-in fibers, there is no migration of fiber material to clog engine oil passages or affect bearing surfaces. According to industry-approved tests, the Champion oil filter traps and holds more dirt and harmful particles during its normal operating time than any other similar filter.



Oil Filters

Full-Flow Spin-On Filters

Champion Replacement Filter Elements



Lycoming

CH48103-1 CH48104-1
(Interchangeable)

CFO-100-1 Short Element

CFO-101-1 Long Element

CFO-205 Element Gasket Kit

Oil Filter Packaging Information

Champion Aerospace spin-on oil filters are packaged in individual boxes, with part numbers displayed prominently. All are equipped with an attached installation gasket. Those with male threaded studs have thread protectors to avoid damage.

All sizes of spin-on filters are packed 12 per case of a single part number, in heavy, reshippable corrugated-board cartons.

Champion oil filter elements are individually boxed, each with a plastic bag containing installation gaskets and instructions. This provides ample protection for these elements in storage and assures availability of necessary items for correct installation.

All sizes of replacement elements are packed 12 per case of a single part number in heavy, reshippable corrugated-board cartons.



Continental

CH48108-1* (TCM No. 649922) CH48109-1* (TCM No. 649923)
(Interchangeable)

Spin-On Oil Filters for Teledyne Continental Motors (TCM) Engines

Champion CH48108-1 and CH48109-1 oil filters have been assigned TCM part numbers 649922 and 649923. Many TCM engines have been modified per TCM service bulletins M74-2, M86-6 (Rev.1), Cessna conversion kits or through local field approval. These modifications may require a different filter part number than the one listed in our application data. Following is a list of filter adapters used on TCM engines with the recommended Champion filter.

Manufacturer	Adapter	Filter
Cessna	1250403-2	CH48110-1
Cessna	1250922-1	CH48110-1
Cessna	1250922-2	CH48110-1
Cessna	1250922-3	CH48110-1
Cessna	1250922-4	CH48109-1
Cessna	1250922-5	CH48108-1
Cessna	0556010-1	CH48110-1
Cessna	0450404-2	CH48110-1
TCM633324	CH48110-1	

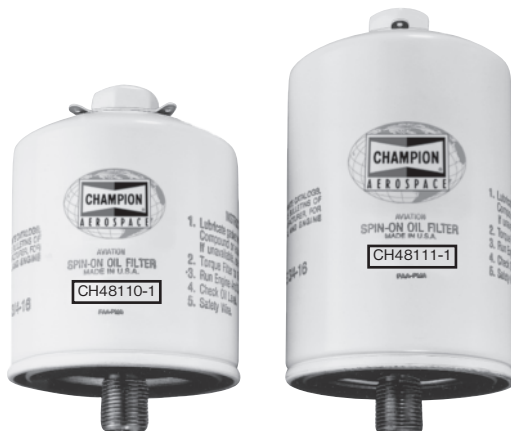

Lycoming and Continental

CH48110-1 CH48111-1
(Interchangeable)

The airframe or engine manufacturer should be consulted for filter application data on field modified engines.

* These filters are equipped with an internal bypass valve. They can be used on any TCM engine equipped with or without a bypass valve in the oil filter engine adapter.

Full-Flow Spin-On Filters

For Lycoming and Continental Engines

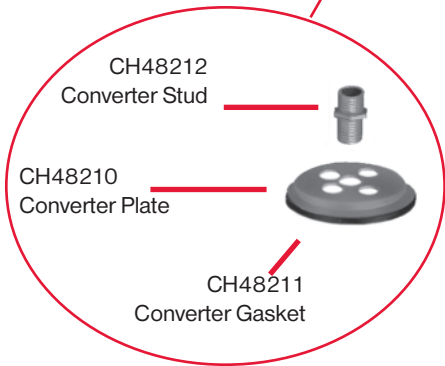

**CH48922 (54E23093)
Spin-On Oil Filter Converter Kit**

Textron Lycoming now supplies the converter kit, formerly sold under Champion P/N: CH48922. This kit is now available from your Lycoming distributor under P/N: 54E23093.



Oil Filters

Aircraft Engine Applications

Model	Engine Model	Champion Spin-On Filter	Champion Element	Model	Engine Model	Champion Spin-On Filter	Champion Element
AEROSPATIALE (Socata)				NOTE: All Cessna aircraft modified under Cessna Service Bulletin SEB-93-1 or MEB 93-1, require Champion Oil Filter CH48108-1. The CH48109-1 may also be used if clearance permits installation.			
TB9 Tampico	O-320-D2A	CH48110-1	CFO-100-1	CESSNA			
TB10 Tobago	O-360-A1AD	CH48110-1	CFO-100-1	150 A thru M	O-200	CH48108-1	CFO-100-1
TB20 Trinidad	IO-540-C4D5D	CH48103-1	CFO-100-1	F150 F thru M	O-200	CH48108-1	CFO-100-1
TB21 Trinidad TC	TIO-540-AB1AD	CH48103-1	CFO-100-1	A150L	O-200	CH48108-1	CFO-100-1
TB30	AEIO-540-L1B5D	CH48103-1	CFO-100-1	FA150	O-200	CH48108-1	CFO-100-1
AEROSTAR (See Piper)				152	O-235-L2C, H2C	CH48110-1	-
BEECH				162	O-200-D	CH48108-1	-
BONANZA				C-172			
E33A, F33A, F33B, F33C	IO-520	-	CFO-100-1	172 A thru H	O-300	CH48108-1	CFO-100-1
E33A, F33A, F33B, F33C	IO-520B	CH48109-1	-	172 I thru M	O-320	CH48110-1	CFO-100-1
G-33	IO-470N	CH48108-1	-	172N	O-320-H2AD	CH48103-1	-
H-35	O-470	CH48108-1	-	172P	O-320-D2J	CH48111-1	CFO-101-1
J, K, M-35	IO 470-C	CH48108-1	-	F172 D thru H	O-300	CH48108-1	CFO-100-1
N, P-35	IO-470-N	CH48108-1	-	FR172 E thru K	IO-360	CH48108-1	CFO-100-1
S35, V35, V35A, V35B	IO-520	-	CFO-100-1	R172K	IO-360-K	CH48108-1	-
S35	IO-520B	CH48109-1	-	172R and S	IO-360-L2A	CH48110-1	-
V35TC, V35A-TC, V35B-TC	TSIO-520	-	CFO-100-1	172RG	O-360-F1A6	CH48110-1	CFO-100-1
V35TC, V35A-TC, -V35B-TC	TSIO-520D	CH48109-1	-	172S	IO-360-L2A	CH48110-1	-
V35, V35A, V35B	IO-520B	CH48109-1	-	177	O-320	CH48110-1	CFO-100-1
36, A36	IO-520B	CH48109-1	-	177A, B	O-360-A1F6D	CH48103-1	CFO-100-1
A36TC, B36TC	TSIO-520-UB	CH48109-1	-	177RG	IO-360-A1B6D	CH48103-1	CFO-100-1
B36-550	IO-550	CH48109-1	-	180 A thru J	O-470	CH48108-1	CFO-100-1
DEBONAIR/BONANZA				180Q	O-470-U++	CH48108-1	CFO-100-1
C33A, E33A, E33C	IO-520	-	CFO-100-1	180-S/N 53087 & Up	1111O-470-U++	CH48108-1	-
C33A, E33A, F33C	IO-520B	CH48109-1	-	C-182			
MUSKETEER				182 A Thru P	O-470	CH48108-1	CFO-100-1
Sport III	O-320	CH48110-1	CFO-100-1	182Q, R	O-470-U++	CH48108-1	CFO-100-1
23	O-320	CH48110-1	CFO-100-1	182S	IO-540-AB1A5	CH48110-1	-
A23-19, 19A, B19 Sport	O-320	CH48110-1	CFO-100-1	A182 K thru N	O-470	CH48108-1	CFO-100-1
A23, 23, A23A	IO-346	-	CFO-100-1	182-S/N 67042 & Up	O-470-U++	CH48108-1	-
A23, A23A	IO-346A	CH48109-1	-	F182-S/N 00130 & Up	O-470-U++	CH48108-1	-
B23, C23 Sundowner	O-360	CH48110-1	CFO-100-1	R182	O-540-J3C5D	CH48103-1	CFO-100-1
B23	O-360A4JD	CH48103-1	CFO-100-1	T182	O-540-L3C5D	CH48103-1	CFO-100-1
SIERRA				TR182, FTR182	O-540-L3C5D	CH48103-1	CFO-100-1
24, A-24, A-24R, B-24R, C-24R	IO-360, -L2A	CH48110-1	CFO-100-1	185 A thru D	IO-470, IO-520	CH48108-1	CFO-100-1
SKIPPER				A185E, F	IO-470, IO-520	CH48108-1	CFO-100-1
77	O-235-L2C	CH48110-1	-	185-S/N 03852 & Up	IO-520	CH48108-1	-
BEECH				188	O-470, IO-520	CH48108-1	CFO-100-1
BARON				188-S/N 03474 & Up	IO-520D	CH48109-1	-
C55, D55, E55, 58	IO-520	-	CFO-100-1	T188-S/N 03474 & Up	TSIO-520	CH48109-1	-
C55, D55, E55, 58	IO-520C	CH48109-1	-	205A	IO-470	CH48108-1	CFO-100-1
56TC, A56TC	TIO-541-E	CH48104-1	CFO-101-1	C-206	IO-540	CH48110-1	CFO-100-1
Baron 58P	TSIO-520-L++	-	CFO-100-1	206 A thru G	IO-520	CH48108-1	CFO-100-1
Baron 58P, 58TC	TSIO-520-L, -W, -B	CH48108-1	-	206H	IO-540-AC1A5	CH48110-1	-
Baron 58C, 550	IO-550	CH48109-1	-	206-S/N 05030 & Up	IO-520	CH48109-1	-
DUKE				206-S/N 05030 & Up	TSIO-520	CH48109-1	-
60, A60, B60	TIO-541	CH48104-1	CFO-101-1	U206	IO-520	CH48108-1	CFO-100-1
QUEEN AIR				T-206H	TIO540-AJ1A	CH48110-1	-
65, 70	IGSO-480	CH48111-1	CFO-101-1	TU-206	TSIO-520	CH48108-1	CFO-100-1
80, 88, B80	IGSO-540	CH48111-1	CFO-101-1	P206	IO-520	CH48108-1	CFO-100-1
TRAVEL AIR				TP206	TSIO-520	CH48108-1	CFO-100-1
95, B95	O-360	CH48110-1	CFO-100-1	207	IO-520	CH48108-1	CFO-100-1
B95A, D95A, E95	IO-360, L2A	CH48110-1	CFO-100-1	207-S/N 05227 & Up	IO-520	CH48109-1	-
DUCHESS				T207-S/N 05227 & Up	TSIO-520	CH48109-1	-
76	LO-360-A1G6D & O-360-A1G6D	CH48103-1		T207	TSIO-520	CH48108-1	CFO-100-1
BELLANCA				210	IO-470, IO-520	CH48108-1	CFO-100-1
17-31A, 17-31ATC	IO-540-K	CH48110-1	CFO-100-1	210-S/N 63373-63375 & Up	IO-520	CH48109-1	-
17-31A Viking	IO-540-K	CH48110-1	CFO-100-1	T210-S/N 63373-63375 & Up	TSIO-520	CH48108-1	-
17-31A Viking	IO-520-D	-	CFO-100-1	P210-S/N 278 & Up	TSIO-520	CH48108-1	-
17-31ATC Turbo	TIO-540	CH48110-1	CFO-100-1	T210, P210-S/N 1-277	TSIO-520++	CH48108-1	CFO-100-1

Aircraft engines not listed, but equipped with oil filters at overhaul, may accept Champion filters. Contact Aviation Service Department for further information. Please include description of your engine. ++ Reference page 25-26 for other TCM application data. * Requires Lyco (54E23093)



Aircraft Engine Applications

Model	Engine Model	Champion Spin-On Filter	Champion Element	Model	Engine Model	Champion Spin-On Filter	Champion Element
CESSNA				MAULE			
T303	LTSIO-520-AE & TSIO-520-AE	CH48109-1	-	M5-180C, MX7-180	O-360-C, -C1F	CH48110-1	
310 C thru Q	IO-470	CH48108-1	CFO-100-1	M5-210C	IO-360D, -L2A	CH48103-1	
310 R	IO-520-M	CH48108-1	-	M5-210TC	TO-360-C1A6D	CH48103-1	
T310P, Q, R	TSIO-520-B	CH48108-1	CFO-100-1	M5-235C, M6-235, M7-235	O-540-J1A5D	CH48103-1	
320-A	TSIO-470	CH48104-1	-	MX-7-235	O-540-W1A5D	CH48103-1	
320-B, C	TSIO-470	CH48109-1	CFO-101-1	MOONEY AIRCRAFT			
320-D	TSIO-520	-	CFO-100-1	M20A, B, Mark21	O-360	CH48110-1	
320-D, E, F	TSIO-520-B	CH48108-1	-	M20D Master	O-360	CH48110-1	CFO-100-1
335	TSIO-520-EB	CH48109-1	-	M20C Ranger	O-360	CH48110-1	
336	IO-360	CH48108-1	CFO-100-1	M20G Statesman	O-360	CH48110-1	CFO-100-1
337	IO-360	CH48108-1	CFO-100-1	M20E Chaparral	IO-360, -L2A	CH48110-1	CFO-100-1
P337, P337H	TSIO-360	CH48108-1	CFO-100-1	M20F Executive	IO-360, -L2A	CH48110-1	CFO-100-1
T337H	TSIO-360-H	CH48108-1	CFO-100-1	M20J-201	IO-360-A3B6D, -L2A	CH48103-1	-
340	TSIO-520-K	CH48108-1	-	M20K-231	TSIO-360-G, LB	CH48108-1	
340A	TSIO-520-N, -NB	CH48109-1	CFO-100-1	M20M-TLS	TIO-540-AFIA, B	CH48110-1	
401/402	TSIO-520-E	CH48108-1	CFO-100-1	M20R	IO-550	CH48108-1	-
402C	TSIO-520-VB	CH48109-1	CFO-100-1	M22 Mustang	TIO-541	CH48110-1	CFO-100-1
404	GTSIO-520-M	CH48111-1	CFO-101-1	M20K-252 TSE	TSIO-360-MB1	CH48108-1	-
411-S/N 000 thru 0126	GTSIO-520-C	CH48104-1	-	PIPER			
411-S/N 0127 and up	GTSIO-520-C	CH48111-1	CFO-101-1	CUB			
414, 414A	TSIO-520-J, -N	CH48108-1	-	PA-18 "150"	O-320	CH48110-1	CFO-100-1
421A, B	GTSIO-520-D, -H,	CH48111-1	CFO-101-1	TRI-PACER			
421C-S/N 1017 thru 1404	-L, -N, ++	CH48111-1	CFO-101-1	PA-22 "150"	O-320	CH48110-1	CFO-100-1
CIRRUS AIRCRAFT				PA-22 "160"	O-320	CH48110-1	CFO-100-1
SRV, SR20	IO-360ES	CH48108-1		COMANCHE			
SR22	IO-550N	CH48109-1		PA-24 "180"	O-360	CH48110-1	CFO-100-1
COLUMBIA/LANCAIR				PA-24 "250"	O-540 or IO-540	CH48110-1	CFO-100-1
COLUMBIA 300, 350	IO-550N	CH48109-1	CFO-100-1	PA-24B, PA-24C "260"	O-540 or IO-540	CH48110-1	CFO-100-1
COLUMBIA 400	TS10-550	CH48109-1	CFO-100-1	PA-24 Turbo "260"	IO-540	CH48110-1	CFO-100-1
DIAMOND AIRCRAFT				PAWNEE			
DA20-1C	IO-240	CH48108-1	CFO-100-1	PA-25 "150"	O-320	CH48110-1	CFO-100-1
DA40-180	IO-360	CH48110-1	CFO-100-1	A25 "260"	O-540	CH48110-1	CFO-100-1
GULFSTREAM AMERICAN (Single Engine Models)				PA-36 Brave	6-285B	CH48109-1	-
AA-1, 1A, 1B, 1B Trainer, TR	2/Lyco O-235	CH48110-1	CFO-100-1	PA-36-375 Brave	IO-720-D1C	CH48110-1	CFO-100-1
A1C Lynx, T-Cat	Lyco O-235-L	CH48110-1	CFO-100-1	PA-36-400 Brave	IO-720D1CD	CH48104-1	CFO-101-1
AA-5 Traveler	Lyco O-320-E	CH48110-1	CFO-100-1	CHEROKEE, CADET			
AA-5A Cheetah	Lyco O-320-E	CH48110-1	CFO-100-1	PA-28 "140"	O-320	CH48110-1	CFO-100-1
AA-5B Tiger	Lyco O-360-A4K	CH48110-1	CFO-100-1	PA-28 "150"	O-320	CH48110-1	CFO-100-1
Cougar	2/Lyco O-320-D	CH48110-1	CFO-100-1	PA-28 "160", "161"	O-320	CH48110-1	CFO-100-1
COMMANDER				PA-28 "180"	O-360	CH48110-1	CFO-100-1
112, 112A	IO-360-C, -L2A	CH48110-1	CFO-100-1	PA-28 "180", "181"	O-360-A4M	CH48110-1	CFO-100-1
112TC	TO-360-C1A6D	CH48103-1	CFO-100-1	PA-28 "235"	O-540	CH48110-1	CFO-100-1
114	IO-540-T4A5D	CH48103-1	CFO-100-1	PA-28 "151"	O-320	CH48110-1	CFO-100-1
500B, 500U	IO-540	CH48110-1	CFO-100-1	ARROW			
700	TIO-540-R2AD	CH48103-1	CFO-100-1	PA-28R "180"	IO-360, L2A	CH48110-1	CFO-100-1
				PA-28R "180"	IO-360-C1CD, L2A	CH48103-1	CFO-100-1
				PA-28R "200"			
				Arrow II	IO-360, L2A	CH48110-1	CFO-100-1
				PA-284 "200"			
				Turbo Arrow III	TSIO-360	CH48108-1	-
				PA-28-R-201T	TSIO-360-F1	CH48108-1	

Aircraft engines not listed, but equipped with oil filters at overhaul, may accept Champion filters. Contact Aviation Service Department for further information. Please include description of your engine. ++ Reference page 25-26 for other TCM application data. * Requires Lyco (54E23093)



Oil Filters

Aircraft Engine Applications

Model	Engine Model	Champion Spin-On Filter	Champion Element	Model	Engine Model	Champion Spin-On Filter	Champion Element
DAKOTA				TWIN COMMANCHE			
PA-28-235	O-540-J3A5D	CH48103-1*	CFO-100-1	PA-30 "160" Turbo	IO-320	CH48110-1	CFO-100-1
PA-28-201T	TSIO-360-FB	CH48108-1	-	PA-39 "160"	IO-320	CH48110-1	CFO-100-1
					LIO-320	CH48110-1	CFO-100-1
CHEROKEE SIX				PA-39 "160" Turbo	IO-320	CH48110-1	CFO-100-1
PA-32 "260"	O-540	CH48110-1	CFO-100-1		LIO-320	CH48110-1	CFO-100-1
PA-32 "300"	IO-540	CH48110-1	CFO-100-1				
PA-32R "300"	IO-540-K1AD	CH48103-1*	CFO-100-1				
PA-32R "300"	TIO-540-S1AD	CH48103-1*	CFO-100-1				
PA-32RT-300T	TIO-540-S1AD	CH48103-1*	CFO-100-1				
PA-32-301	IO-540-K1G5D	CH48103-1*	CFO-100-1				
PA-32-301	TIO-540-S1AD	CH48103-1*	CFO-100-1				
PA-32R-301	IO-540-K1G5D	CH48103-1*	CFO-100-1				
PA-32R-301	TIO-540-S1AD	CH48103-1*	CFO-100-1				
TOMAHAWK							
Trainer PA-38-112	O-235-L2C	CH48103-1*	CFO-100-1				
MALIBU				SENECA			
PA-46-301P	Cont TSIO-520-BE	CH48109-1		PA-34	IO-360C	CH48110-1	CFO-100-1
					LIO-360C	CH48110-1	CFO-100-1
MALIBU MIRAGE				PA-34	IO-360-C1E6D	CH48103-1	CFO-100-1
PA-46-350-P	Lycos TIO-540-AE2A	CH48103-1		Seneca II	LIO-360-C1E6D	CH48103-1	CFO-100-1
					LTSIO-360-E	CH48108-1	-
APACHE				Seneca III	TSIO-360-E	CH48108-1	-
PA-23 "150"	O-320	CH48110-1	CFO-100-1	PA-34-220T	TSIO-360-KB	CH48108-1	
PA-23 "160"	O-320	CH48110-1	CFO-100-1		LTSIO-360-KB	CH48108-1	
PA-23 "235"	O-540	CH48110-1	CFO-100-1				
AZTEC				PIPER AEROSTAR			
PA-23 "250"	O-540	CH48110-1	CFO-100-1	PA-60-600, -600A	IO-540-G, -K	CH48110-1	CFO-100-1
"C" PA-23	IO-540	CH48110-1	CFO-100-1	PA-60-604, -601B	IO-540-P, -S	CH48110-1	CFO-100-1
PA-23 Turbo "250"	IO-540	CH48110-1	CFO-100-1	PA-60-601P	IO-540-S	CH48110-1	CFO-100-1
"C", "D", "E", "F"				PA-60-602P	IO-540-AA1A5	CH48110-1	CFO-100-1
PA-23 Turbo "250"	TIO-540	CH48110-1	CFO-100-1				
				SEMINOLE			
				PA-44-180	O-360-E1AD	CH48103-1*	CFO-100-1
				PA-44-180T	TO-360-E1A6D	CH48103-1*	CFO-100-1
					LTO-360-E1A6D		

Dimensional Data

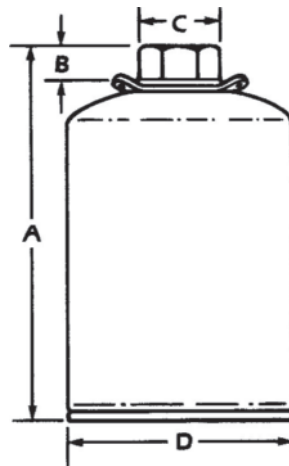

Popular spin-on oil filters

Champion Part No.	A	B	C	D	Thread (SAE)	Dry Weight Lbs./Kg.
CH48103-1	4.48" (11.4 cm)	0.43" (1.09 cm)	1.00" Hex (2.54 cm)	3.71" (9.4 cm)	13/16-16-UNS-2B	1.32lbs. (0.59kg)
CH48104-1	5.73" (14.6 cm)	0.43" (1.09 cm)	1.00" Hex (2.54 cm)	3.71" (9.4 cm)	13/16-16-UNS-2B	1.41lbs. (0.64kg)
CH48108-1	4.48" (11.4 cm)	0.43" (1.09 cm)	1.00" Hex (2.54 cm)	3.71" (9.4 cm)	3/4-16-UNF-2B	1.40lbs. (0.64kg)
CH48109-1	5.73" (14.6 cm)	0.43" (1.09 cm)	1.00" Hex (2.54 cm)	3.71" (9.4 cm)	3/4-16-UNF-2B	1.51lbs. (0.68kg)
CH48110-1	4.48" (11.4 cm)	0.43" (1.09 cm)	1.00" Hex (2.54 cm)	3.71" (9.4 cm)	3/4-16-UNF-2A	1.38lbs. (0.63kg)
CH48111-1	5.73" (14.6 cm)	0.43" (1.09 cm)	1.00" Hex (2.54 cm)	3.71" (9.4 cm)	3/4-16-UNF-2A	1.47lbs. (0.67kg)

Aircraft engines not listed, but equipped with oil filters at overhaul, may accept Champion filters. Write Aviation Service Department for further information. Please include description of your engine.

* Requires Lyco (54E23093)

Turbine Exciters



Product Features

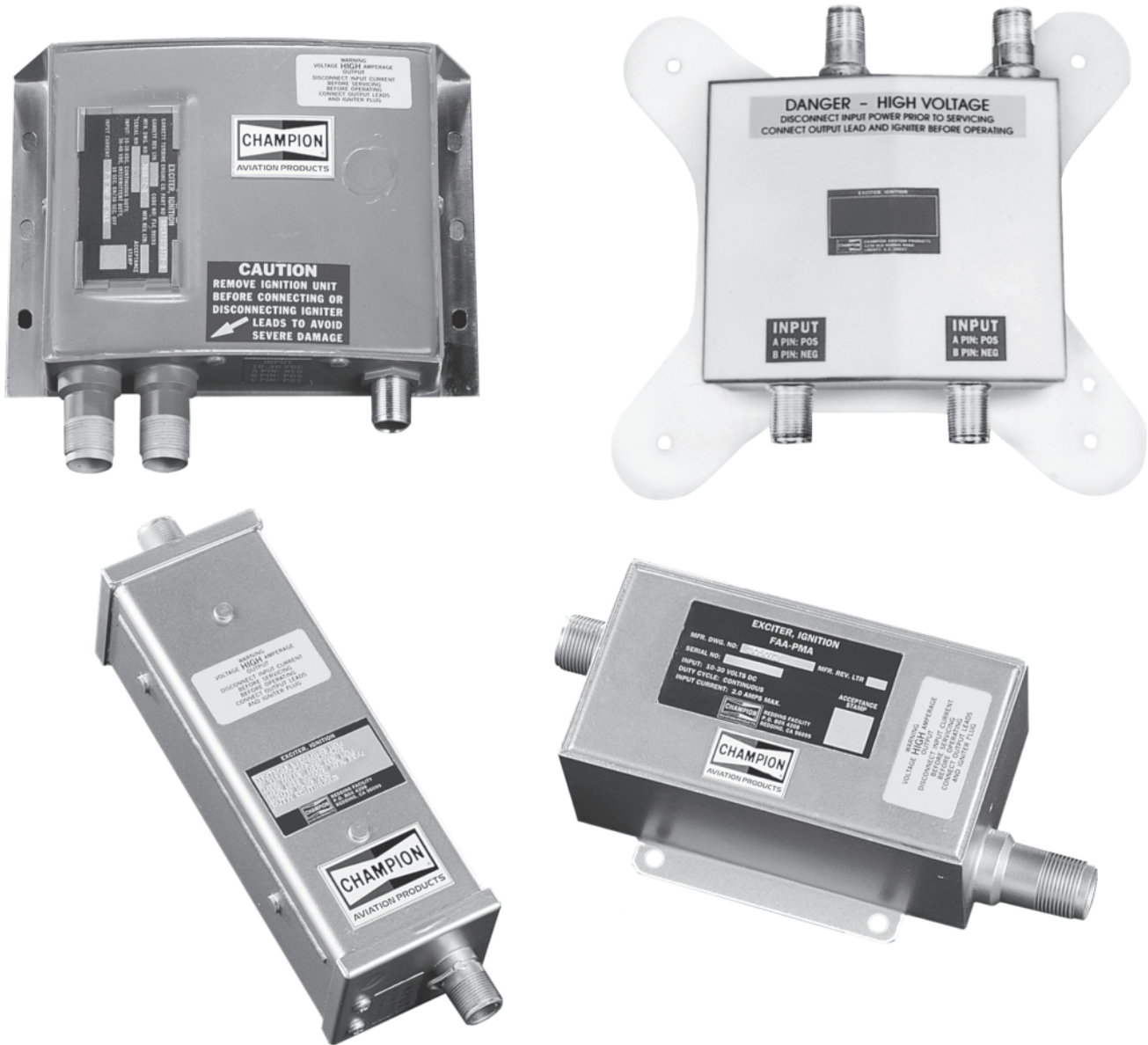

Turbine Exciters

Champion Quality and Reliability.

Every Champion Aerospace exciter carries our full warranty and is backed by the Champion name. Our exciters are built to the same exacting standards that have made us a leader in aviation products for over 75 years.

Champion Exciters are Widely Used in the Following Engine Applications:

- | | |
|------------------------------|--|
| Honeywell: | AS907, TPE331, TFE731, ALF502,
LF507, 131-9A/B, 331-600 |
| Pratt & Whitney: | PW150, PW206, PW308, JT15D, PT6A, PT6C, PW207 |
| Sundstrand: | APS2000 |
| Williams/Rolls-Royce: | FJ44-1A, FJ33 |





Turbine Exciters

Aircraft Engine Applications

Engine Application	Champion Part Number	OEM Part Number	Applications
Honeywell Engines			
HTF7000 (formerly AS907) TPE331-10U, -11, -12, -14A/14B TFE731-2-1C/-2B TFE731-3-1C/1E TFE731-3-1F/1G TFE731-3A-2B/-200G TFE731-3AR/200G TFE731-3B-100S TFE731-3BR-100S TFE731-3R-1D TFE731-5-1B, -5A-1C, -5R-1H ALF 502R-3, -3A, -5 ALF 502L, L2, L2A, L2C, L3 LF507-1F, 1H 131-9B 131-9A 331-600	CH92074-2 305012-2 305050 CH92036 CH92036	3038100-5 3070378-2 2-303-026-02 3888058-7 3888058-7	Boeing 737-600,-700,-800 Airbus A319, A320, A321, 340-500, -600
Pratt & Whitney Canada			
JT15D-1, -1A, -1B, -4, -4B, -4D, -5, 5A PW150	CH92028 CH92043-2 CH92043-3	3041996-01 3122413-07 3122413-08	
PW308C	CH92051-3 CH92051-4	30C1132-04 30C1132-05	
PW307A	CH92083-5 CH92083-6	30P0604-06 30P0604-07	
PW206A, B, B2, C, E, PW207C, D, D1, D2, E, PT6C-67C, -67D	CH92015 CH92106	3043937-01, -02, -03	
PT6A-21, -27, -28, -34, -34AG, -34B, -36, -41, -42, -52, -60A, -61, -65B, -67B, -67D, -67P, -114, -114A, -135, -135A, PT6C-67C, PT6T-3, -3B, -3E, -3BF, -3BG	CH92015-1 CH92106-1	3043937-04 3043937-06	
PW308A	CH92090-1 CH92090-2	30C4946-02 30C4946-03	
Sundstrand APIC (Auxiliary Power International)			
APS 2000	305088-2	179420-2	Boeing 737-300, -400, -500
APS2300	CH92073-1	4952793	
Williams International/Rolls-Royce			
FJ44 Series	CH92007-1	68145	Citation Jet, CJ1, CJ2
FJ33	CH92070-1	71294	

Notes

*FAA-PMA Pending.

Turbine Ignition Leads



Product Features

Contact Assembly - Provides sure sparks and clean, positive contact between lead, igniter and exciter.

Military-Grade Stainless Steel Shielding - Provides positive RFI protection and resists abrasion.

Core Assembly - Meets stringent OEM and military requirements and provides maximum spark efficiency and insulation value.



Champion Aerospace provides OEMs with high-quality, military-grade ignition leads manufactured with technology designed for the 21st century. Champion is a full ignition system supplier to the turbine engine market.

Champion has moved rapidly to supply the turbine aftermarket with top-quality, cost-effective replacement leads, as well as offering a lead overhaul program, a unique maintenance alternative. Regular, preventive maintenance helps avoid costly, unscheduled maintenance caused by worn turbine ignition leads. Often, cables that do not appear worn, but have weak shielding or poor connections can actually be about to fail. Whether you buy new FAA-PMA approved replacement leads or choose to overhaul your current leads, you're assured of quality, prompt delivery and maximum reliability.

Turbine Ignition Leads



Turbine Ignition Leads

Aircraft Engine Applications

ENGINE APPLICATION	CHAMPION LEAD NO.	OEM LEAD NO.	AIRCRAFT APPLICATIONS
Allison Engine Company (Rolls-Royce)			
250-B17C (All), -B17D (All), -B17E, -B17F (All), -B17F/1, -B17F2, -C20S	CH53351	23060813	
250-C18, -C18A, -C18B, -C18C5, -C19, -C20, -C20B (All), -C20 (T63-A-720), -C20J (All), -C20R/1, -C20R/2 (All), -C204/4	53247	23060814	
250-C30 (All), -C30G, -C30G/2, -C30M, -C30S, -C40B	53158	23060815	
250-C20W, -C30 (All), -C30G, -C30L, -C30M, -C30P, -C30R, -C30R/1, -C30S, -C30U, -C47B, -C47M	53159	23060816	
250-C28B, -C28C	53153	22306817	
250-C20F, -C20R (All)	53270	23060818	
General Electric			
CF34-3A1, -3B, -3B1	CH53515-3 CH53515-4	4096T96P03 4096T96P04	
CF34-8C1, C5	CH53515-1 CH53515-2	4096T96P07 4096T96P08	
CF34-8C5A1/A3	CH53515-1 CH53515-5	4096T96P07 4096T96P11	
CFE738-1, -1B	53323-4	3051406-4	
Honeywell			
ALF502L-2, -2A, -2C, -3	53282 (Jumper) 53283 (Jumper)	2-303-025-02 2-303-079-02	Canadair Challenger 600
ALF502R-3, -3A, -5, -6	53214 (Jumper A) 53215 (Jumper B) 53214, 53215, (Jumper)	2-303-766-02 2-303-767-02 2-303-766-02, 2-303-767-02	BAe 146-10 BAe 146-300 Series
	53216-1, 53217-1 (Ign. A, B) 53217-1, (Ign. B)	2-303-768-03 2-303-769-03 2-303-769-03	
LF507-IF, -IH	53214 (Jumper A) 53215 (Jumper B) 53216-1 (Ign. A)	2-303-766-02 2-303-767-02 2-303-768-03	AVRO RJ Series (Formerly BAe)
LF507-1F, 1H, AS907-1, 1A	53217-1 (Ign. B) 53280-1 53281-1 53282 (Jumper B) 53283 (Jumper B)	2-303-769-03 2-303-742-03 2-303-743-03 2-303-025-02 2-303-079-02	AVRO RJ Series (Formerly BAe)
HTF7000 (formerly AS907)	53542-1	3038111-1	Challenger 300
TPE331-25DA	50221-18	369876-18	
TPE331-25FA	50221-21	369876-21	Air Asia, Porter
TPE 331-2-0014	50221-15 50221-16	369876-15 369876-16	Skyvan
TPE331-2UA-203D	50221-12	369876-12	Alaska Wildlife, DHC3 Beaver,
TPE331-55B TPE331-1-101E TPE331-1-101Z TPE331-3U-303V	50221-7	369876-7	Carstedt, Jetliner 600A Jetliner 600B Marsh, Turbo Thrush Handley Page, Jetstream III
TPE331-10UF-501H TPE331-10UF-511H TPE331-10UF-512H TPE331-10UF-513H TPE331-10UG-513H TPE331-10UG-514H TPE331-10UGR-513H	50221-24 50221-25	369876-24 369876-25	CASA-212 Jetstream 31 Merlin 300 MU-2

This chart is for reference only. Lead installation may change as a result of variations in ignition system configuration. Consult latest revision of the appropriate illustrated parts catalog for specific data. Champion FAA-PMA leads are manufactured by Champion Aerospace LLC

38 Contact your preferred distributor for Champion factory FAA certified lead overhaul program.

Turbine Ignition Leads



Aircraft Engine Applications

ENGINE APPLICATION	CHAMPION LEAD NO.	OEM LEAD NO.	AIRCRAFT APPLICATIONS
Honeywell (Cont'd)			
TPE331-10UGR-514H	50221-24	369876-24	Cessna, 441 Conquest
TPE331-10UR-513H	50221-25	369876-25	Fairchild, IV/Metro I, IVA/Metro II
TPE331-8-401S			
TPE331-8-402S			
TPE331-8-403S			
TPE331-3UW-303G			
TPE331-3U-303G			
TPE331-3-303G			
TPE331-3-304G			
TPE331-6-252B	50221-24	369876-24	Bech, B-100 King Air
TPE331-2-201C	50221-8	369876-8	CASA, 212-100
TPE331-5-251C			212-100
TPE331-10-501C			980/1000
TPE331-10-511C			Mitsubishi, Marquise, Solitaire
TPE331-5-252D	50221-22	369876-22	Dornier, 228
TPE331-5-252K	50221-9	369876-9	690B
TPE331-5-252M			MU-2N
TPE331-1-151A			MU-2DP, MU-2F, MU-2G
TPE331-1-151G	50221-15	369876-15	Merlin IIB
	50221-16	369876-16	
TPE331-10UA-501G	50221-24	369876-24	Merlin III, IIIA, IV, IVA,
TPE331-10UA-511G	50221-29	369876-29	Metro II-10
TPE331-10U-511G	50221-24	369876-24	Merlin IIIB
TPE331-10U-512G	50221-28	369876-28	Merlin IIIC
TPE331-10U-513G	50221-32		Merlin IVC, Metro III
TPE331-11U-612G	50221-33		Metro, II, IIA
TPE331-43A	50221-7	369876-7	Gulfstream Commander,
TPE331-43B	50221-9	369876-9	680T, 680V, 680W, 681
TPE331-5-251K	50221-12	369876-12	690/690A
TPE331-5-254K	50221-9	369876-9	840
TPE331-6-251M			MU-2K, MU-2L, MU-2M, MU-2S
TPE331-25AA	50221-19	369876-19	MU-2B
TPE331-25AB	50221-9	369876-9	MU-2D
TPE331-14A-601P	53133-5	3105589-5	
	53133-6	3105589-6	Piper, Cheyenne 400LS
TPE331-14GR/HR	53338-1	3105901-1	Jetstream 41
	53339-1	3105902-1	
TPE331-14, -14A, -14B, -15	53133-5	3105589-5	
TPE331-14, -14A, -14B	53133-6	3105589-6	Piper, Cheyenne 400LS
TPE351-20	53133-7	3105589-7	
TFE731-2, -3, -3A, -3AR, -3-1F, -3B, -3BR, -3R, -5R	53142-10	3071590-10	AAC, HS125-700
	53142-11	3071590-11	
TFE731-3-1E	53142-10	3071590-10	Jetstar 731
TFE731-3-1G	53142-11	3071590-11	IAI, 1124 Westwind,
TFE731-3-5A-1C			Sabreliner 65, Falcon 50
TFE731-3R-1H	53142-10	3071590-10	BAe, HS125-700
TFE731-3B-100S	53142-11	3071590-11	Cessna, Citation III, Citation VII
TFE731-2, -3A, -3BR-100S	53142-12	3071590-12	
TFE731-3A-2B, -3B, -3R	53142-13	3071590-13	
TFE731-3AR			
TFE731-4R-2S			

This chart is for reference only. Lead installation may change as a result of variations in ignition system configuration. Consult latest revision of the appropriate illustrated parts catalog for specific data. Champion FAA-PMA leads are manufactured by Champion Aerospace LLC



Turbine Ignition Leads

Aircraft Engine Applications

ENGINE APPLICATION	CHAMPION LEAD NO.	OEM LEAD NO.	AIRCRAFT APPLICATIONS
Honeywell (Cont'd)			
TFE731-5R-1H	53142-10	3071590-10	HS125-800
TFE731-3-1F	53142-11	3071590-11	Lockheed, Jetstar
TFE731-2-1C	53142-12	3071590-12	Dassault, Falcon 10/100
TFE731-3AR-200G	53142-13	3071590-13	1125 Astra
TFE731-3A-200G			Model 55
TFE731-5A-1C	53142-12	3071590-12	Falcon 900
TFE731-5-1B	53142-13	3071590-13	L55
TFE731-2-2B	53142-12+(Pre S.B. 74-3003) 53142-13+(Pre S.B. 74-3003) 53142-10++(Post S.B. 74-3003) 53142-11++(Post S.B. 74-3003)	3071590-12 3071590-13 3071590-10 3071590-11	Learjet, L35/36
TFE731-3R-1D	53142-12+(Pre S.B. 74-3003) 53142-13+(Pre S.B. 74-3003)	3071590-12 3071590-13	
Pratt & Whitney CANADA PT-6 Series			
PT6A-11 PT6A-110 PT6A-21	53402-02	3011871	Piper Cheyenne I/IA, T1040 Dornier Skyservant Beech C90 Cessna Caravan II*, Conquest I,
PT6A-112	CH53399-04	3119832-01	Embraer EMB-110 P1, P2 EMB-111
PT6A-114, 114A PT6A-135A PT6A-11AG PT6A-116, 121	CH53399-04 CH53399-04	3119832-01 3119832-01	Cessna Caravan I*, Avtek 400, Beech F90-1, Omac Laser 300 Ayers Turbo Thrush T-11, Schweizer G164B Turbine, Agcat Jetcrafters Taurus, Piper
PT6A-135	CH53399-04	3119832-01	Cheyenne IIXL, Riley Eagle 421, Riley Turbine 210, Schafer Comanchero
PT6A-15AG	CH53399-04	3119832-01	Air Tractor AT400, Ayers Turbo Thrush T-15, Frakes Turbo Cat B Weatherly 620TP
PT6A, 6A, 6B PT6A-20 PT6A-20A, 20B PT6A-25 PT6A-25A PT6A-25C PT6A-36, 34, 38 PT6A-62 PT6A-66 PT6A-67, 114, 114A, 135A PT6A-67D	CH53399-04 CH53399-07* CH53399-09 CH53399-10	3119832-01 3119833-01 3119832-02 3119835-02	DHC-2-Turbo Beaver, Beech, C90/A C90A, 99, Schafer Comanchero 500, Beech 99A/B, Catic Y-12, DHC-6 Twin Otter, Embraer EMB-110/B, B1, C, E, & P, Caraja, Let L-410A, Pilatus PC-6 Beech T34C, Beech T34C-1,1900D, NAC1T, Pilatus PC-7, Embraer EMB-312, Beech C99, Arava, Pilatus PC-9, Piaggio Avanti, Beech Starship I
PT6A-28	CH53399-04	3119832-01	Ratheon Beech 1900 / 1900C Beech E90, 99A, A100, Embraer EMB-121A, Piper Cheyenne II
PT6A-34	CH53399-04	3119832-01	Avalon 680, Embraer EMB-110K1, S1, P1, P2, Frakes Mallard, IAI Arava, IAI 102, Omni Turbo Titan, Spectrum One
PT6A-34AG PT6A-41 PT6A-42, 42A PT6A-45A PT6A-45B PT6A-52 PT6A-60A, 60AG PT6A-61, 64 PT6A-65/65B, 65AG, 66, 66A, 66B, 66D, 67, 67A, 67B, 67D, 67F, 67R, 67T, 67AF, 6B PT6A-65R/AR	CH53399-04 CH53399-06	3119832-01 3119836-01	Ayres Turbo Thrush T34, Frakes Turbo Cat A, B, C, NAC Fieldmaster, PzL 106A Turbo Kruk, Schweizer G164B Turbine, Agcat Beech 200, Piper Cheyenne III, Beech B200, C12S, Pilatus PC-9, Frakes Mohawk 198, Shorts 330, Beech 300, Piper Cheyenne IIIA, Beech 1900, Hawk Gafhawk 125, Shorts 360

This chart is for reference only. Lead installation may change as a result of variations in ignition system configuration. Consult latest revision of the appropriate illustrated parts catalog for specific data. Champion FAA-PMA leads are manufactured by Champion Aerospace LLC

* Cessna Caravan, New Lead Routing Procedure, Outside Plenum. See PWC Service Bulletin 1512.

40 Contact your preferred distributor for Champion factory FAA certified lead overhaul program.

Turbine Ignition Leads



Aircraft Engine Applications

ENGINE APPLICATION	CHAMPION LEAD NO.	OEM LEAD NO.	AIRCRAFT APPLICATIONS
Pratt & Whitney CANADA PT-6 Series (Cont'd)			
PT6A-41AG	CH53399-06	3119836-01	Frakes Turbo-CAT, Schweizer G-164D
PT6A-45R	CH53399-06	3119836-01	Fairchild Metro IIIA, Hawk Gaffhawk 125, Shorts 330, Shorts C23A Sherpa, USAC Turbo
PT6A-50	CH53399-05	3119835-01	DHC-7
PT6B-36/36A/36B/35F	CH53463	3123061-01	Sikorsky S-76, H-76
PT 6C-67C	CH53490	3050604-01	
PT6T-36			
PT6T-3B/3B1/6/3BE/3D	CH53399-01	3119829-01	Bell 212, 412, Sikorsky S58T
Pratt & Whitney CANADA JT15D Series			
JT15D			Aerospatiale Corvette
JT15D-1	53067-21 (Pin Connector) T3	3107371-01	Cessna Citation 500
JT15D-1A/1B	53067-38.5 (Pin Connector) T3	3107371-02	Cessna Citation I
JT15D-4			Cessna Citation II,
JT15D-4B			Mitsubishi Diamond I
JT15D-4C			Cessna Citation S/II
JT15D-4D			S211
JT15D-5,5A,5D	53300-1 (Button Connector) T5	3118347-01	Mitsubishi Diamond IA
JT15D-5,5A,5D,5F	53300-2 (Button Connector) T5	3118347-02	Beechjet, T-47A
Reference PWC Service Bulletin to Retrofit JT15D-4 to 53300-1 & 53300-2. Also See Igniter Plug Listing.			
Pratt & Whitney CANADA PW100 Series*			
PW115, 118, 118A, 199B, 120, 121, 120A	53367-01	3120676-01	Embraer EMB-120
PW123/123AF	50383H	3033339	Dornier 328
PW124B/125B	53302	3038915	ATR-42
PW126/126A	53335-01 (Ceramic)	3117291-01	DHC-8-100
PW127 H	50383-K	3035333	BAe ATP
	53335-01	3117291-01	
PW150/150A	CH53536	3056566-01	Dash 8Q, 400
	CH53456-2	3122414-04	DeHavilland
Pratt & Whitney CANADA PW200 Series*			
PW206A, C, E	CH53442-4	3121144-02	MD900, Augusta AIO9E
	CH53530	3056743-01	MD Explorer, Bell 427, EC135
PW206B	CH53442-3	3122957-01	EC135, Augusta AIO9E
PW207C, D, E	CH53442-4	3121144-02	
Pratt & Whitney CANADA PW300 Series			
PW305,306, A, B, C	CH53238-1	31B3615-02	BAe 1000, Lear 60
PW307A	CH53544-1	30P0605-02	
PW308A, C	CH53483-5	30C1133-03	Dassault- Falcon EX 2000
Turbomeca			
Arriel 1A, -1A1, -1A2, -1B, -1D, -1D1, -1S, -1S1	53317-3	9550166530	
Williams International/Rolls-Royce			
FJ44- Series	53221	50853	Cessna Citation Jet, CJ 1,2,3
	53279	50852	Swearingen/Jaffe SJ-30
Turbine Engine Applications (APU)			
Honeywell			
36-100E	50160-61	369259-61	CL 6013A
36-100 (M) -150 (M)	53359-3	3888302-3	BAe 146, 146-300 Embraer 120 BAe ATP 125-800/-1000 Cessna 650 Saab 340 IAI Astea 1125
36-150 (A), (AA), (J), (W), (CX)	53359-6	3888302-6	Falcon 20-5

This chart is for reference only. Lead installation may change as a result of variations in ignition system configuration. Consult latest revision of the appropriate illustrated parts catalog for specific data. Champion FAA-PMA leads are manufactured by Champion Aerospace LLC

**Type "2" ignition systems require Champion P/N 50383K (PWC P/N 3035333) *FAA-PMA Pending



Turbine Ignition Leads

Turbine Engine Applications (APU)

ENGINE APPLICATION	CHAMPION LEAD NO.	OEM LEAD NO.	AIRCRAFT APPLICATIONS
Honeywell (Formerly Allied Signal Engines) (Cont'd)			
36-150 (R)	53359-9	3888302-9	Fokker 100
	53359-15	3888302-15	
36-150 (RJ)	53359-16	3888302-16	Canadair CL-RJ
36-150 (RR)	53359-18	3888302-18	Fokker 100
	53236-5	304269-5	
36-208B	53179-1	3876132-1	Boeing 737-300, 400, 500
36-300	53179-8	3876132-8	Airbus A320, A321
85 Series	50160-7	369259-7	Boeing 727-100, 200, Boeing 737-200,
131-9D	50160-20	369259-20	300, 400, DC 9, 10, 30, 50, MD80
	53368-1	3888316-1	MD90
	53109-3	3888076-3	Boeing 757, 767
331-200,-250	53109-1, 2	388076-1, 2	Airbus A300, A310
	53179-6	3876132-6	
331-350C 53179-7	3876132-7	Airbus A330, A340	
	50160-47	369259-47	DC10, MD11
TSCP 700 50160-48	369259-48	Airbus A300B	
Pratt & Whitney CANADA			
RE100(LJ)	53359-22	3888302-22	LearJet 45/45XR
ST6L-73	CH53399-08	3119834-01	Lockheed L-1011
PW901A	50383-L	3910351-01	Boeing 747-400
Sundstrand APIC (Auxiliary Power International)			
	53267-3	179505-3	
APS2000	53267-4	179505-4	Boeing 737-300, -400, -500
REPAIR KITS			
TPE331	53051	<i>(Use 52243 Crimp Tool)</i>	
TFE731	53164-3, -4	<i>(Use 52243 Crimp Tool) (-4 Includes Extension Ferrule)</i>	
PW100	53369		
PT6	53100-1, 53436		
PW305	53434		
UNIVERSAL KIT			
PT-6 Series, PW100 Series, PW205 Series	53057	<i>(PWC PN 3108407-01)</i>	
OPTIONAL TOOLS FOR REPAIR			
Crimp Tool (Ref. Sat-124)	52243		
Contact Hook	52258		

NOTES

This chart is for reference only. Lead installation may change as a result of variations in ignition system configuration. Consult latest revision of the appropriate illustrated parts catalog for specific data. Champion FAA-PMA leads are manufactured by Champion Aerospace LLC
 *Type "2" ignition systems require Champion P/N 50383K (PWC P/N 3035333)

General Aviation Igniters



Product Features

Corrosion Protection

Silver-plated shell for protection against corrosion and seizing.

Leakage Protection

Dual seals for protection against gas leakage under high temperature conditions.

Protective Coating

Special coating prevents excessive chafing of shell, extending igniter service life.

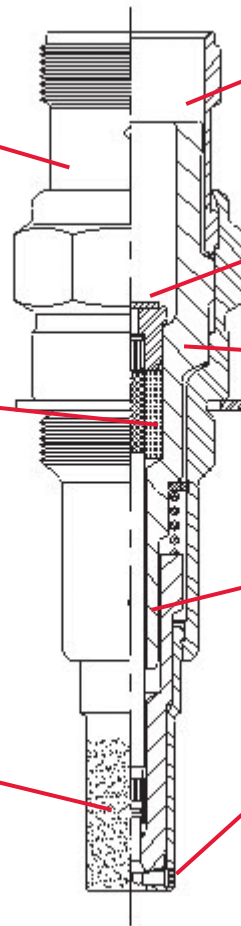

Coated Bushing

Bushing coated to prevent lead sticking, allowing for easier removal and installation.

Tungsten Contact

Provides increased resistance to arcing with mating lead.

Positive Insulator Retention

Upper insulator shaped to provide positive component retention.

Shaped Insulator

Lower insulator shaped to provide positive component retention.

Patented Iridium Pin Design

Provides maximum resistance to spark erosion and increased service life.



Turbine Igniters

Design Features

Champion turbine igniters are a product of the Champion Aerospace commitment to the highest standards of quality and technology, a commitment that has made Champion the #1 choice of engine manufacturers, maintenance technicians and pilots around the world.

Champion-engineered safety-retention features are the best in the business and Champion developments in the turbine igniter design include fuel drain slots which keep the igniter from quenching out, air-cooling holes for longer life and engobe semi-conductive materials for quicker, more reliable starts.



Champion Turbine Igniters cover over 300 different engine designs and are OEM on:
Allison, Honeywell, General Electric, Pratt & Whitney, Sundstrand/Turbomeca, Teledyne, Textron Lycoming, Williams International, Westinghouse and Rolls-Royce.



General Aviation Igniters

For airline igniter applications consult Champion Aerospace AV-22 catalog.

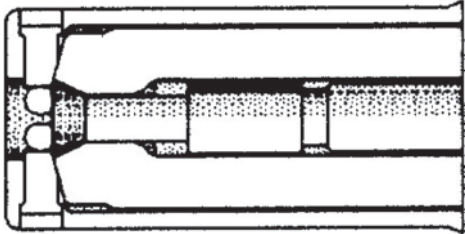
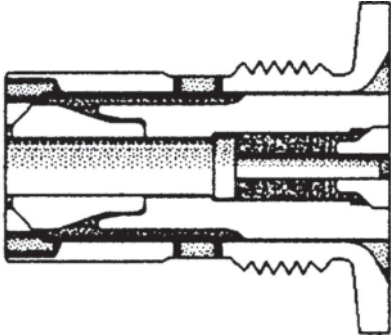
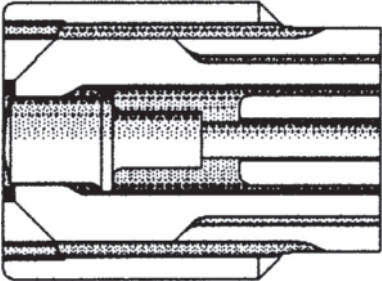
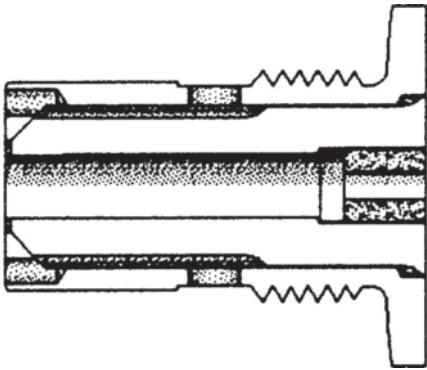
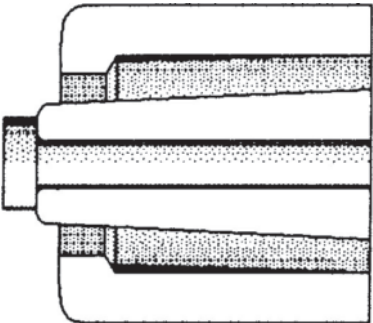
Illustrated below are six plug designs by firing end configuration.

Gap Description	Typical Firing End Configuration	Gap Description	Typical Firing End Configuration
High-Voltage Recessed Surface Gap (Long Life)		Low-Voltage Surface Gap (Solid Semiconductor)	
High-Voltage Surface Gap		Low-Voltage Shunted Surface Gap	
High-Voltage Air Gap		Low-Voltage Glow Coil Element	

Igniter Replacement Gaskets

M-677	FS118-1, FS153-1, CH31547C, CH31615 (6800087)	CH63038	CH31753A, CH31773 (6800848) (nickel)
CH63008	FHE205, FHE267-2A (6800148)	6800847	CH31753A, CH31773 (cemented)
CH63037	AA138S (6800158) (copper)	6800948	CH31772A, CH31785, CH31806
6860337	PT6 & PW100	6860326	JT15D

General Aviation Igniters



For airline igniter applications consult Champion Aerospace AV-22 catalog.

Engine Mfr. & Model	(FAA Approved)		PRIMARY PROPULSION PLANT	
	Champion Part No.	Engine Mfr. Part No.	Aircraft Make	Aircraft Model
ALLISON (Rolls-Royce)				
501-D13, -D13A, D, E, H, -D22	FS89-1	6805734	Lockheed	Convair 580, Electra, 382 Hercules
501-D22A, C, G	FS109-1A	6847727	Lockheed	L-100 Series Hercules, Convair 580A
250-B15, -B15A, -B15E, -B15G, -B17 -B17B, -B17C, -B17D, -B17E, -C10, -C10A, -C10B, -C10D, -C18, -C18A, -C18B, -C18C, -C20, -C20B, -C20C, -C20F, -C20J, -C20R/1, -C20R/2, -C20R/4, -C20S, -C20W	CH34168 or CH34269 (long life)	6877518 23006266	Aerospace Tech of Australia Aerospatiale Agusta Bell Breda Helio Hiller Aviation Hindustan	Nomad 22B, N24A Twin Star AS355F-1, -2, M2, A5 555 UR - C 1 9 , 109A 206B 369D H634 Twin RH1100A HTT-34
250-B15A, -B15E, -B15G, -B17D, -B17E, -B17F, -B17F/1, -B17F/2, -C18, -C18C, -C18, -C18C, -C20J, -C20R, -C20R/1, -C20R/2, -C20R/4, -C20S, -C20W	YB63-1	1017565	MBB McDonnell Douglas Panstwowe Zaklady Partenavia Pilatus BN Schweizer SIAI Marchetti Soloy (Bell)	BO105, 105CB, 105CBS MD500, 500U, D, E, (MD-88) MI-2 AP-68TP-300 Spartacus Turbine Islander 330 SF260TP, SF600 47-Conversion
250-C28, -C28B, -C28C, -C30, -C30G, -C30G2, -C30L, -C30M, -C30P, -C30R, -C30S, -C30R/3M, -C30R/1, -C30R/3, -C30U -C40, -C40B, -C47, -C47B, -C47E, -C47M	CH34187-A or CH34304 (long life)	6899084 23006267	Bell MBB Boeing Sikorsky	Long Ranger-206-L1, 206-L3, 214, 222, 407, 430 BO-105LS-A3 530F, G, N S-76A MKII
GMA 2100A, AE2100, -2100A, -2100C, -2100D3, AE3007	CH31898-1	23062672	SAAB Embraer Cessna	2000, C-130J EMB 135, 140, 145 Citation X
GENERAL ELECTRIC				
CJ610	FHE146-7A	37C311124	Hansa Gates	HFB320 LearJet 23, 24B, 24D, 25, 25B, 25C, 25D, 25G
CF700	FHE146-7A	37C311124	Dassault Sabreliner Corp.	Falcon 20, D, E, F Sabreliner 75A
CF34-1A CF34-3A (Before S/N 350336) CF34-3A (After S/N 350336) CF34-3A (After S/N 350336) CF34-3A1, -3A2, -3B CF34-3A1, -3B1 CF34-8C1, -8C5 CF34-8E CF34-10E	FHE256-10A FHE256-10A FHE256-10B CH34661 CH31858-1, -2 CH31858-1, -2 CH31926 CH31926 CH31900-6 CH31965	4048T30P06 4048T30P06 4048T30P07 4048T30P10 4096T33P07 1374M13P11	Canadair Canadair Canadair Canadair Canadair Canadair Embraer Embraer	Challenger 601/601-3A Challenger 601/601-3A Challenger 601/601-3A Challenger 601/601-3A Challenger 601-3R/604 Bombardier CRJ-100/200 Bombardier CRJ-700-900 170/175 190/195
CT64-820-4	FHE111-30	4026T27P01		
CT7-2A, T700-T2C	CH34158	4053T22P01	Westland	W30, 200, 300/404
CT7-2A, CT7-2B, T700-T2C	CH34439	4053T22P06	Sikorsky Bell	570DC 214ST
CT7-2A, -2D1, -5A, -5A1, -5A2, -5A3, -6, -6A, -7A, -7A1, -8, -9B, -9B1, -9B2, -9C, -9D	CH34419	5044T67P07	Saab-Fairchild Sikorsky Casa EH Indust.	SF340 S-92 CN235 EN101
CT-58-100-2, -110-1, -110-2, -140-1, -140A/L -140-2	CH34095	37B200275P102	AgustaAS-61 Kawasaki Mitsubishi	KV-10711/11A SH-3B, S-61A
HONEYWELL (formally Alliedsignal Engines)				
TPE331	CH31547C**	369949-3	CASA Commander Div. Beech King Air B100 British Aerospace Cessna Dornier Fairchild Mitsubishi	C212-200, -300 680T, V, W, 681, 690A, B, 840, 900, 980, 1000 Jetstream 31 Conquest II 228-100-200, 101, 201, 212 Merlin IIB, IVC, Metro-III, SA-227-AT, AC, TT/41 MU2B, D, F, G, J, K, MU2B-40, MU2B-60, MY2S

* Includes Installation Gaskets.



General Aviation Igniters

For airline igniter applications consult Champion Aerospace AV-22 catalog.

Engine Mfr. & Model	(FAA Approved)		PRIMARY PROPULSION PLANT	
	Champion Part No.	Engine Mfr. Part No.	Aircraft Make	Aircraft Model
HONEYWELL (formally Alliedsignal Engines)				
TPE331-14, -14A, -14B	CH31701A	3105547-1	Piper	Cheyenne 400
TPE331-14 GR/HR	Y209-2 CH34627-1	3105893-4 3105893-5	British Aerospace	Jetsream 41
TFE731-2, -3, -3A, -3B, -3R, -3AB, -3AR, -3B, -4R-2S, -5, -5A, -5R, -5AR	CH31815-2 (long life) CH31621A	3074541-4 3070967-1	Cessna Dassault Bombardier British Aerospace	Citation III, Citation VII Falcon 10A, 50, 100, 900, CASA 101 Lear Jet 31, 35, 36, 54, 56, LR55-ER, -LR, XLR 125-700, 731, 800
TFE731, -20, -40, -60	CH31815-2	3074541-4	Israel Aircraft Ind Lockheed Sabreliner Corp	Westwind 1124, 1124A, Astra 1125 Jetstar II, 731 Sabreliner 65/65A
ATF3-6, -6A Requires both numbers listed	CH31641 (lower) or CH31642 (upper) CH31767 (lower) (long life) CH31768 (upper) (long life)	3001430-1 3001430-2 3003119-1 3003119-2	Dassault	Falcon 200, French Guardian, HU-25A
T53-07A, T53-09A, B, C, T53-11A, T53-13B, T53-17A, T53-13A	FHE113-10 CH34016-1	1-300-197-03 1-300-348-06	Bell Bell	204B, 205 205A
LTS-101-600A, -600B, 650A-2, 650-A1, 750A-1	CH34016-1	1-300-348-06	Aerospatiale	AS350, AS350D Astar, SA-633G1, Dauphin 2
LTS-101-650C-2, -650C-3, -650C-3A, 600A-2, -650B-1, -600A3, -750B-1, -750C-1	CH34016-1	1-300-348-07	Bell	214A, 222, 222B, 222U, 222UT
LTP-101-600A-1A -700A-1A	CH34016-1	1-300-348-07	MBB/Kawasaki Air Tractor Piaggio	BK-117-A3 AT-302 P166-DL3 Page AG-Cat B, Thrush
ALF-502-L, -L2, -L2A, -L2C, -L3, -R3, -R3A, -R4, -R5, -R6	CH34452A	2-300-732-05	Canadair British Aerospace	Challenger CL600 BAe 146-100, 200, 300, QT
AL-512	CH34135	2-300-821-01	Boeing Vertol	Chinook 234, 234ER, 234LR, 234MLR, 234U
LF507-1F, -1H	CH34452A	2-300-732-05	Fadec equipped	AVRO-RJ Series
HTF7000 (formerly AS907)	CH34826-6*	3038110-6	Bombardier	Challenger 300
PRATT & WHITNEY				
JT12A, -4, -5A, -6, -6A, -8 J60-P-5B	FHE151 or AA33S, A, D	424815 424848-E	Lockheed Sabreliner Corp.	Jetstar Sabreliner 40, 60
JTFD12A	FHE151	424815	Sikorsky	CH54A, S-64E, -F, Skycrane
PRATT & WHITNEY CANADA, INC.				
(Glow Plug Ignition)				
PT6A-6, -6A, -B, -11, -11AG-20, -15AG -20A, -20B, -21, -25, -25A, -27, -28, -28A, -29, -34, -34B, -36, -110	AGF2-6	3014054	Beech DeHavilland	KingAir Commuter 90, A90, B90, C90, E90, 99 & 100, A100 Turbo Beaver, Twin Otter
PT6A-29, -34B, -AG, -36, -38, -40, -41, -41AG, -42, -45A/B/R, -50, -60A, -61A, -65B/R/AG/AR, -110, -112, -114, -116, -121, -135A	CH34055 or CH34406	3035102 3035882	Aerospatiale Agusta-Bell Airtractor, Inc. AVTEK Ayers Beech Bell Cessna DeHavilland Dornier Embraer	TBM 700 AB-212, AB-412 AT-400, AT-400A, AT-402, AT-502, AT-503 400 Turbo Thrush S2R-T C-90, King Air-200, F90A, 1900, 300, 350, 212, 412 Conquest 1, Caravan I, II Dash 7 DO-128-6, DO-24-TT, Seastar Bandeirante, Xingu, Appjost, Tucano
PT6B-9, -35F, -36A, -36B				
PT6C-67A, 67C	CH34758-2	3050627-03	Frakes	Mohawk 298, Turbo-Cat S2-R, AB139

* FAA-PMA Pending

**Includes Installation Gaskets

General Aviation Igniters



For airline igniter applications consult Champion Aerospace AV-22 catalog.

Engine Mfr. & Model	(FAA Approved)		PRIMARY PROPULSION PLANT	
	Champion Part No.	Engine Mfr. Part No.	Aircraft Make	Aircraft Model
PRATT & WHITNEY CANADA, INC. (Cont'd)				
PT6T-3, -3A, -3B, -3BE, -3D, -3DE, -3DF PT6A, PT6B, PT6T Series (Spark Ignition)	CH34406 or CH34055	3035882 3035102 (IC 3032096)	Bell Piaggio Pilatus Piper Short Bros Sikorsky Westland	212, 412 Avanti, P180 PC-6, -7, -12 Cheyenne, I, II, III, IIIA, IIXL, TIO40 SD-330, 360 S58T, S76B Lynx
PW-100, -115, -118, -119B, -120, -120A, -121, -123/B/C/E, 123AF, -124/A/B, -125B, -126, -126A, -127E	CH34817 CH34055 or CH34406	3055161-01 3035102 3035882	Aerospatiale/Aeritalia British Aerospace DeHavilland Dornier Embraer Fokker	ATR-42, 72 ATP DASH 8 328 EMB 120, 121, Caraja 50
PW150, A	CH31918-2 CH31955-1	3122415-03 3056557-02	DeHavilland	Dash 8/400
PW206 A	CH34643-1	3120953-01	Eurocopter	EC135
PW206A, B, B2, C, E	CH34723	3120880-01	McDonnell Douglas	MD900, A109E, B0108, EC135
PW305A, 305B, 306A, 306B, 306C	CH34682**	31B5168-01 31B5268-01	British Aerospace Lear	BAe 1000, Cessna Sovereign, 328 Jet G200
PW307	CH31958-3	30P0606-03	Dassault	Falcon 7X
PW308A, C	CH31929-4	30C1356-04	Raytheon, Dassault	Hawker Horizon, Falcon 2000EX
PW500 Series	CH34804-3	9058600-1	Cessna	Bravo, Encore, Excel
JT15D, -1, -1A, -1B, -41, -4B, -4C, -4D, -5, -5A, -5B, -5C, -5D, -5F	CH34668-1 (T5) CH34659-3 (T5) Long Life FHE246-4 (T3)	3117463-01 3119400-01 3039828	Aerospatiale Cessna Beech SIAI-Marchetti	Corvette SN601 Citation I, II, SII, 5 Ultra MU-300 Diamond I, IA, II, Beechjet 400 S211
ROLLS ROYCE				
BR700, 710A1-10, 710A2-20	Y242-5	Y242-5	Gulfstream	GV, Canadiar Global Express
BR710	Y242-5	Y242-5	Bombardier	Global Express
BR715	CH34760-1	CH34760-1		
Dart	FHE19-6L	CR104-2	Convair Fokker, Fairchild Gulfstream NAMC	600, 640 F27, FH227 Gulfstream I, Albatross YS-11
R-R Snecma M45H-Mark 501	CH34126	CBS113-1, 2	Fokker	VFW614
Spey RB168, RB183, 506-14, -14A, -14C, -14D, 511-14, -14W, -8, 511-8/Model 2970, 555-15/H	FHE164E YW90	CR114-2 L912017	Gulfstream British Aerospace Fokker	GII, III 111 F28
Bristol Siddeley-Viper 500 Series, MK521, 522, 526 R.R. Viper	FHE205B	CBS116	Beech Hawker Siddeley Piaggio	BH-125 HS-125 PD-808
Bristol Siddeley-Viper 600 Series, MK601-22, R.R. Viper TAY 611-8, 611-8C, 620-15, 650-14, 650-15	FHE267-2A** Y183-5	CBS111-2 L912019	Hawker Siddeley Gulfstream Fokker	HS125-600 GIV, GIV-SP F100, F70
TAY 650-14, 650-15, 651-54 Incorporating modification 72-1302	Y183-6	L912023	Folker	F100
TURBOMECA				
Ariel 1A, -1A1, -1A2, -1B, -1C, -1C1, -1C2, -1D -1D1, 1E2, -1K, -1K1, 1S, -1S1, 2C1, 2C2	CH34745	9550175400	Agusta Eurocopter Sikorsky	109K Astar, AS350, BK117, EC145, EC155 S-76
Ariel 1A, -1A1, -1A2, -1B, -1D, -1D1, 1S, -1S1, -2B, 2C	CH34595	9550168770	Eurocopter	AS350, AS365NE, EC120, EC130, EC135
Arrius 2F, 2B, 2B1, -2B2	CH34593	9550166660	Eurocopter	EC-120
WALTER				
M601E-11, M601F	CH34630			Let L-420, PZL-106 BT
WILLIAMS INTERNATIONAL/ROLLS-ROYCE				
FJ44-1A, -2A, -2C	CH31956	68032	Cessna Raytheon Swearingen	Citation Jet, CJ1, CJ2, CJ3, CJ4 Premier I SJ30
FJ33	CH34812-2	67906	Adam Aircraft	A700

* FAA-PMA Pending

** Includes Installation Gaskets



General Aviation APU Igniters

For airline igniter applications consult Champion Aerospace AV-22 catalog.

Engine Mfr. & Model	(FAA Approved)		PRIMARY PROPULSION PLANT	
	Champion Part No.	Engine Mfr. Part No.	Aircraft Make	Aircraft Model
TURBINE ENGINE APPLICATIONS (APU)				
AUXILIARY POWER INTERNATIONAL CORP.				
APS500-T62T-40C14 APS1000 (T-62T-46C) APS2100	CH38013	160544-1	Fokker Embraer Saab Avro	50 (F27 Mark 050) EMB-135, -145 2000 146-RJ70A, 85A, 100A
APS2300	CH34848	4952647	British Aerospace	BAe 146-100A, 200A, 300A
HAMILTON SUNSTRAND				
T20G Gemini	CH38013	160544-1	Beech Cessna Gulfstream Aerospace Gulfstream Commander Israel Aircraft Lear Mitsubishi/Beech Piper Swearingen	King Air Citation I, II 980 Commodore Jet Lear Jet Diamond I, MU-2 Cheyenne Merlin, Metro
T62T-39 T62T-40C Series (APS 500)	FHE159-6	26519-1	Boeing Boeing Vertol Cessna Convair Dassault DeHavilland Cessna Fairchild Gulfstream BAe Raytheon Lockheed Sabreliner Corp.	707 Model 234 Citation III 880 Falcon 20, 20D, 50 Dash 7, Dash 8 Citation III, VI, VII FH227 II 125-400, -600, -700, -800, -1000 Beech Jet Jetstar Sabreliner
T62T-40C14-APS 500 R/C14 is installed	CH34834	4952382	Embraer	ERJ 135/145, Emb 120
HONEYWELL				
85-37 85-71, -90E P85-90F	FS47-11	75153	Grumman Convair	Gulfstream I 580
85-91C 85-98/C/CK 85-98/CK (A) 85-980/W/DCK/DHF 85-99 85-115/C/CK 85-115H 85-129/-129A, C, E, F, G 85-139/H 85-163/CK 85-185L 85-291C 85-291E 30-54 30-95, 141 30-92	CH31723 or CH31824 FS47-11 CH31615** CH31615**	369162 3888210-1 75153 369964-5 369964-5	Convair 580 Sud Aviation British Aerospace Hawker Siddeley Hawker Siddeley Aerospatiale Convair Fairchild Convair Hawker Siddeley Lockheed Dassault	Caravelle BAe III Trident III Trident I & II Mercure 2 580 (Avensa) F27 600 DH125 Jetstar Falcon

**Includes Installation Gaskets *FAA-PMA Pending

48 Contact your preferred distributor for Champion factory FAA certified Igniter inspection program.

General Aviation APU Igniters



For airline igniter applications consult Champion Aerospace AV-22 catalog.

(FAA Approved)		AUXILIARY AIRBORNE TURBINE UNIT		
Engine Mfr. & Model	Champion Part No.	Engine Mfr. Part No.	Aircraft Make	Aircraft Model
HONEYWELL (Cont.)				
36-4A 36-6 36-16/-16A 36-28 36-50	CH31615** FHE159-6	369964-5 3888002-1	Fokker Grumman NAMC Fokker Fokker	F28 GII YS-11 VFW614 F28
36-100 (E), (M)	CH34249 or CH34492 or CH31713 CH34553 CH34585	3888096-1 3888096-2 369964-6 3888096-3 3888096-4	Dassault Canadair Fokker Hawker Siddeley DeHavilland British Aerospace Canadair	Falcon 50, Falcon 20G CL-600, 601, 604 F28 HS125-700 DHC-5 BAe146-100/200 CL-RJ, CRJ200
36-150RJ 36-150 Series (Except-F2M)	CH34549 CH34313	304634-2 3888002-2 Fokker IAI	Embraer British Aerospace Aeritalia Aerospaziale Dassault Cessna Dornier AstrA 1125 Saab-Fairchild	EMB-120 BAe/AERO 146-300, 125-800/1000 ATR-42 Falcon 900, 20-5 Citation III, X 100 DO-328 340
36-150 (RJ) (RR)	CH34549	304634-2	Bombardier Fokker	CL601, RJ100, 200, Falcon 2000, 2000EX, Fokker-100, 100
36-150 F2M	CH34706	3888002-5	Falcon	2000
RE220 (RJ)	CH31930	WB3888446-1	Bombardier	Global Express, CRJ 700, 900
RE220 (GV)	CH34730 (Series 21)	WB3888401-1	Gulfstream	GV
RE100 (LJ)	CH34549	304634-2	Learjet	Learjet 45/45XR
TURBINE ENGINE APPLICATIONS (GPU)				
Engine Mfr. & Model	Champion Part No.		Engine Mfr. Part No.	Applications
ALLIEDSIGNAL AUXILIARY POWER (ASAP)				
85-90	FS47-11 (HV) or		75153	Various Ground Power Equipment Manufacturers
85-91	FHE118 (LV), (-1B)			
85-291	CH31723 or		373399 or 369162	Various Ground Power Equipment Manufacturers
85-184	CH31824 (long life)		3888210-1	
PRATT & WHITNEY CANADA, INC.				
ST6L-77	CH34055	3035102	AIRCO	

* FAA-PMA Pending

**Includes Installation Gaskets

NOTES



Table of Contents



MODEL/PART NO.	EQUIPMENT DESCRIPTION	PAGE
Model 2600A & 2600AX-CE*	Spark Plug Vibrator Cleaner	52
Model CT-475AV-CE*	Cleaner and Tester	52
CT-906	Plug Master Flex-Handle Ratchet Wrench	53
CT-907	Plug Mate Magnetic Spark Plug Socket	53
No. 2612	Spark Plug Lubricant	53
CT-709	Oil Filter Wrench	54
CT-913A, B	Lead-Master Wrenches	53
CT-456A	Spark Plug/Igniter Viewer	53
CT-496	Igniter Lead Connector Wear Gauge	54
CT-497	Igniter Lead Connector Wear Gauge	54
CT-911 & CT-912	T-Handle Wrenches	53
CT-449	Thread Clean-Out Tool	54
CT-457	Fine Wire Gap-Setting Tool	54
CT-415AV	Gap-Setting Tool	54
CT-450	Retractable Gap Gauge	54
Model 2500A	Gap-Setting Tool	56
CT-494	Igniter Erosion Gauge	55
No. 52243	Crimping Tool	54
CT-446	Spark Plug Tray	54
CT-923	Oil Filter Can Cutter	55
CT-924	Can Holder	55
CT-925	Media Cutter	55
CT-492	Igniter Erosion Gauge	55
CT-498	Igniter Erosion Gauge	55
No. 91893	Abrasive Compound	55

*Pending Approval



Service Tools & Equipment

Model 2600A

Spark Plug Vibrator Cleaner

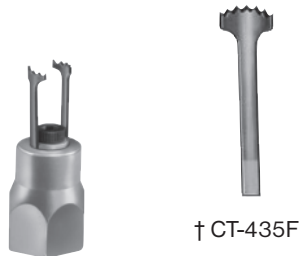

† CT-435A Assembly
Fine Wire and Two Prong

The Champion vibrator cleaner has been designed to clean fine-wire or massive-electrode spark plugs that accumulate heavy lead compound deposits. Such deposits are virtually impossible to remove with standard abrasive cleaners.

- Quick-change cleaning head assemblies
- Easy replacement of single cutter blades
- Powerful vibrator drive unit for reliability and long life
- Flexible rubber mounting for portable or permanent bench installation

Specifications

Size: 5 1/4" x 4 1/4" x 7 1/2"
(13.4 x 10.8 x 18.7 cm.)
Shipping Wt: 7 lbs. (3.2 kg)
(incl. accessories)
Carton Size: 8" x 8" x 8"
(20.0 x 20.0 x 20.0 cm.)
Electrical Requirements: 110 V 60 Hz

ACCESSORY PARTS LIST

Qty.	Description	Champion P/N
1 ea.	Vibrator Drive Unit	
1 ea. †	Single Head Assembly A	CT-435A
10 ea. †	Full Cutter Blades (1 pkg)	CT-435F
1 ea. †	9/64 Allen Wrench	

† Parts standard with Model 2600A.

REPLACEMENT PARTS LIST

Part No.	Description
2600-4	Switch
2600-6	Adjustment Stud
2600-7	5/16" - 18 Stop Nut
2600-10	Vibrator Damper
2600-11	Vibrator Unit
2600-19	#8-32 X 1/4" Set Screw

Contact Champion for parts other than those listed.

Model CT-475AV

Spark Plug Service Unit



Cleaner & Tester

For Cleaning: Two flexible rubber adapters handle 14 and 18mm plug types.

Specifications

Size: 11 1/2" x 16 3/8" x 12 1/8" (29.2 x 41.5 x 30.7 cm)
Shipping Weight: 15 lbs. (6.80 kg)
Color: Grey, Red, Black
Compressed Air Required: 125 - 180psi (8.9 - 12.8 kg/cm²)
Electrical Requirements: 115V
Carton Size: 12 1/2" x 13" x 17 1/2" (31.8 x 33.0 x 44.5 cm)

Note: Use 91893 abrasive charge only. (See Replacement Parts List.)
Model 800 Cleaners, use two (2) charges.

For Testing: Steel adapters of 14 and 18 mm are standard equipment and conveniently stored on top of cleaner for ready availability. Molded of rugged A. B. S. plastic which is durable, oil resistant and easy to clean. An aluminum-base frame is included, which permits easy mounting to a work bench and quick removal.

The solid state ignition system produces a stable ignition test voltage providing greater accuracy and reliability. Its lack of moving parts eliminates the major cause of tester failures.

Cleaning is by a dry-abrasive air blast, which quickly and effectively removes conductive deposits.

All compressed air for both cleaning and testing passes through a "built-in" automatic water trap to stop harmful air line moisture.





REPLACEMENT PARTS LIST

Description	Part No.
Water Trap	91010
Airline Section L2	91053
Steel Adapter 18mm	91096
Airline Section L5	91138
Mirror	91836
Rubber Adapter 14mm	91657 (5502)
Abrasive Charge	91893(533)
Steel Adapter 14mm	91299
Airline Section L3	92048
Rubber Adapter 18mm	92203 (5-503)
Ignition System Retro Fit Kit	91817
Red and Black Knob Kit	92401
Adapter Hold Down Cap	92463
Switch-Push Button	92487
Valve Stem, Knob & O' Ring	92548
Cleaner Valve Assembly	92746
Water Trap Bowl Kit	92784 (L300)
Cleaner Bag/Manifold Assembly	93095
Airline Section L1	93250
Steel Nozzle Jet	93274 (5-512)
Compression Chamber Assembly	93330
Elect. Control Module/Switch & Leads	93415
Cleaner & Bag (CT-475 Only)	93453
Coil (CT-475 Only)	93519
Rubber Nozzle Tip	94023 (622)
Hinge and Spring Kit	94245
Air Inlet Nipple/Mounting Nut	94283
Airline Section L4	94306
Abrasive Shield	94486
Compression Gauge	94523
Shielding Barrel Contact	94783 (8-683)
Cleaner Bag Model 800, 2400	8-813

LICENSE ARRANGEMENT: Champion service tools are distributed under license by Ideal Aviation, Mesa, AZ.

Service Tools & Equipment



		
CT-906	CT-907	No. 91893
Plug Master Flex-Handle Ratchet Wrench (Formerly CT-405)	Magnetic Spark Plug Socket (Formerly CT-430)	Abrasive Compound
<p>Especially designed to make spark plug removal and installation easier and faster. Flex-handle allows 30° angle travel in either direction. Extra fine reversible ratchet action requires only 6° travel for next bit. Popular 3/8" (0.95 cm) square drive fits Model CT-907 and other standard sockets. Knurled handle, rust-resistant chrome finish.</p> <p><u>Approximate Length:</u> 11" (27.9 cm) long</p> <p><u>Weight:</u> 12 oz. (340 g) Packed individually.</p>	<p>A companion tool to the champion plug-master and other 3/8" (0.95 cm) square drive wrench handles. Especially designed for shielded aviation spark plugs. Built-in permanent Alnico magnet holds plugs firmly, practically eliminating dropped plugs.</p> <p><u>Finish:</u> Chrome</p> <p><u>Length:</u> 3-1/2" (8.9 cm) 1/2" (0.95 cm) square drive 7/8" (2.2 cm) deep hex.</p> <p><u>Weight:</u> 8-1/2" oz. (241 g) Packed individually.</p>	<p>No. 91893 abrasive compound replaces #533 abrasive in all Champion spark plug cleaner units. Cleaners formerly using the #533 abrasive will require two bags of 91893 to fully charge the unit. The chart below should be followed when replacing abrasive:</p> <ol style="list-style-type: none"> 1. Use two bags of 91893 abrasive to fully charge Champion 2400, 800H, 800E and 700 cleaners. 2. Use one bag of 91893 to fully charge the CT475AV cleaner/tester. <p>#622 Teflon nozzle tip sold separately.</p>
		
CT-913A, B	CT-911 & CT-912	No. 2612
LeadMaster Wrenches	T-Handle Wrenches	Spark Plug Thread Lubricant
<p>Lead-Master wrenches reduce time to remove and install spark plug ignition leads, also permits short arc turning due to 12-point grip head.</p> <p><u>Shipping Weight:</u> 9 oz. (280 g)</p>	<p>CT-911 Special 3/4" (1.9 cm) open box wrench.</p> <p><u>Shipping Weight:</u> 4 oz. (112 g)</p> <p>CT-912 Special 7/8" (2.2 cm) open box wrench.</p> <p><u>Shipping Weight:</u> 4 oz. (112 g)</p>	<p>A high-temperature, graphited lubricant for application to spark plug installation threads to prevent galling and seizure. Sturdy plastic 4 fl. oz. bottle with brush attached to cap.</p> <p><u>Size:</u> 5-5/8" x 7-1/4" x 5-1/4" (14.4 x 18.4 x 13.3 cm)</p> <p><u>Shipping Weight:</u> 4 lbs. (1.814 kg)</p>

LICENSE ARRANGEMENT: Champion service tools are distributed under license by Ideal Aviation, Mesa, AZ.



Service Tools & Equipment



CT-496

Igniter Lead Connector Wear Gauge

Igniter lead connector wear gauge for ARP670 type 2M fittings common to PT6 leads and others. Features a calibrated pin to measure connector wear. Opposite end sized to measure neoprene grommet expansion.



CT-709

Oil Filter Wrench

Designed for easy removal of Cessna oil filter adapters from 150 Series thru 300 Series aircraft. Manufactured from tool quality steel, features both 3/8" and 1/2" drives, as well as "flip over" reversability.

Shipping Weight: 11 oz. (311 g)

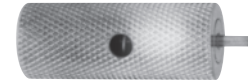

CT-497

Igniter Lead Wear Gauge

Igniter lead connector wear gauge for ARP670 Type 3M fittings common to TPE6331, TFE731 leads and others. Features a spring weighted pin for an accurate "pull test" of connectors.

Size: 15/16" (3.33 cm)

Shipping Weight: 11 oz. (311 g)

Carton Size: 3-1/2" x 1-1/4" x 1-1/4"
(8.89 x 3.18 x 3.18 cm)

Note: Many leads incorporate type 2M & 3M connectors at opposite ends. Both CT-496 & CT-497 gauges are recommended.



CT-449

Thread Clean-Out Tool

For cleaning aircraft engine spark plug 18 mm bushings to assure correct installation of new or overhauled spark plugs. Regular 7/8" (2.22 cm) hex fits spark plug sockets. Precision ground threads, three deep flutes retain carbon debris.

Approximate Length: 4" (10.1 cm) long

Weight: 7 oz. (198 g) Packed individually.



CT-415AV

Gap Setting Tool w/ 7/8" Thread Adapter w/ CT-466

A low-cost efficient gap setting tool for closing gaps on massive electrode-type aviation spark plugs. Designed for use as a hand tool, for mounting on a bench, or to be held in a vise. Complete with one adapter for 18mm massive plugs (Part No. GT-204) and one CT-450 gap gauge. Also includes GT-208 adapter for regapping REM37BY plugs.

Size: 7-1/2" (19.5 cm) High

Weight: 1-1/2 lbs. (0.68 kg)
Packed individually.

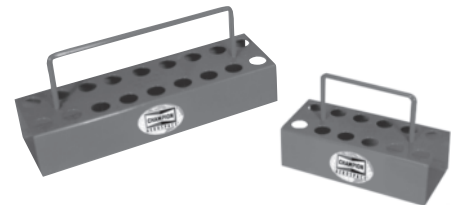

CT-446 & CT-446-18

Spark Plug Tray

Sturdy steel tray holds up to 12 or 18 aviation spark plugs. Speeds handling of used or new plugs. Holes numbered to correspond with engine cylinders. Protects against shielding barrel contamination. Flat rubber, non-slip pads.

Approx. Length: 5" x 8" x 3-1/2"
(12.7 x 20.3 x 8.9 cm)

Weight: 7 oz. (198 g) Packed individually.



CT-450

Retractable Gap Gauge

High impact red plastic case contains 4 sets of accurate retractable go and no go wire gauges:

2 sets: .015 - .019 (.016 Nom)
(0.40 - 0.50 mm)

2 sets: .018 - .022 (.019 Nom)
(0.45 - 0.55 mm)

Size: 3-1/2" (8.9 cm) long

Weight: 1-1/4 oz. (35 g)

Replacement package of 4 wire gauge sets complete as described above. Order Part No. CT-450-WG.



CT-457

Fine Wire Gap Setting Tool

Designed exclusively for adjusting fine wire electrode spark plug gaps. Slot fits iridium ground electrodes for quick, safe adjustment.

Size: 2-1/4" x 2" x 1/4" (5.7 x 5.0 x 0.63 cm)

Weight: 1/2 oz. (14 g) Packed individually.

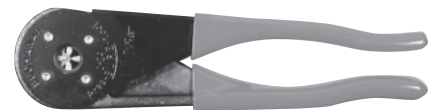

No. 52243

Crimping Tool

A special tool used to crimp turbine ignition lead contacts to the unshield center wire.

Shipping Weight: 14.4 oz. (408 g)

LICENSE ARRANGEMENT: Champion service tools are distributed under license by Ideal Aviation, Mesa, AZ.

Service Tools & Equipment

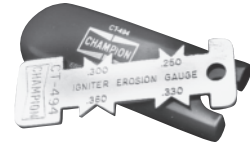
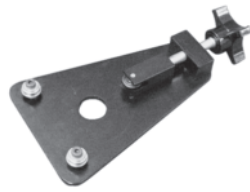

CT-923

Can Cutter

The new improved CT923 Cutter allows for oil filters to be cut in either direction. This is a complete tool with no parts or adapters to change. It is very easy to use, and will provide a simple effective means of cutting open oil filters. The cutter blades in the CT923 are the same blades that are used in the CT470. Also cuts the Champion RBC308 filter used on the Rotax 912 and 914 engines.

NOTE: CT-923-4 Cutter Blade

CT-494

Igniter Erosion Gauge

The CT-494 accurately determines wear on 10 of our most popular surface gap igniters. Insuring maximum igniter life without exceeding safe wear limitations. For use with following igniters:

CH31547, CH31621, CH34055, CH34168, CH34187, CH34269, CH34304, CH34406, FHE146-7 and FHE246-4
Heavy duty protective sleeve included.

Shipping Weight: 1 oz. (28 g)

CT-921

Oil Filter Torque Wrench



The CT-921 can be used for oil filter installation and removal. It is calibrated to 17 foot pounds, the recommended torque. Can easily be recalibrated when necessary.
1" Hex.

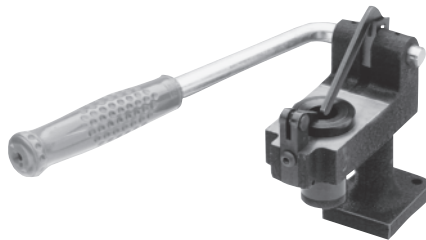

CT-2500A

Gap Setting Tool

Complete with accessories and gauges listed below, instructions for use. Packed individually, partially assembled.

Size: 6" x 5 1/2" x 6" (15.2 x 13.9 x 15.2 cm)

Handle Size: 9 1/2" (24.1 cm) long

Shipping weight: 5 1/2 lbs. (2.49 kg)

A precision gap-setting tool for all massive-electrode Champion spark plugs. Permits simultaneous adjustment of two opposite prongs without removing the spacing gauge. Designed for permanent installation on bench or heavy wooden board.

Replacement Parts For 2500A Gap Setting Tool:

CT-458-2	Lever
CT-458-3	Toggle Link
CT-458-4	Toggle Arm (<i>Long Top Arm</i>)
CT-458-5	Toggle Pin
CT-458-6	Stationary Finger
CT-458-7	Stationary Finger Support
CT-458-10	Upper Collet Bushing
CT-458-11	Centering Bushing
CT-458-12	Collet Adjustment Bushing
CT-458-13	Spring Pin
CT-458-15	Finger Pin
GT-1-17L	Spacing Gauge .015" (0.15-.019/0.40-0.50mm)
GT-1-17J	Spacing Gauge .018" (0.36 - 0.46mm)
GT-1-27	Spacing Gauge Handle Assembly

Note: Parts not listed are either standard or not normally required.

Accessories Packaged in Model 2500A Gap Setting Tool:

10 Qty.	GT-1-17L	Spacing Gauge .015 - .019" (0.40 - 0.50 mm)
1 Qty.	GT-1-27	Spacing Gauge Handle Assembly.

LICENSE ARRANGEMENT: Champion service tools are distributed under license by Ideal Aviation, Mesa, AZ.



Service Tools & Equipment

Current/Discontinued Aviation Spark Plugs

SIZE	CURRENT PLUG TYPES	DISCONTINUED PLUG TYPES
18mm 1/2" Reach:	M40J* M41E REM40E REM38E REM38S RHM40E RHM40E RHM38E RHM38S	AY4 M42E, M41N, D41N, C27, C26 EM41E, EM42E, ED41N, C27S, C26S, REM39N, RED39N, RC26S REM37N, RED37N, R25S REM38P, REM38W HM41E RHM39N, RHD39N RHM37N, RHD37N RHM38P, RHM38W
18mm 13/16" Reach:	REB37E REB36S REB32E - RHB37E - RHB32E RHB29E RHB36S RHB32S RHB27S RHB27S	REB37N, REA37N, R37S-1, RC35S, C35S, REB87N, REA87N, REB36W, R819, HO14S REB32N, REA32N, R56S, RC34S, C34S REB29N, REA29N, R33S RHB38E, RHB37N, RHA37E, RHA37N, RHB87N, RHA87N, R119, R115 RHB32N, RHB33E, RHA32E, RHA32N, R111 RHB29N, RHA29E, RHA29N, R103 R214D, RHB36P, RHB36W RHB32P, RHB32W RHB27P RHB27W
18mm 1-1/8" Reach:	RHU32E RHU27E RHU32S	RHU37E RHU30P, RHU30W
14mm 3/8" Reach:	REJ38 NON-SHIELDED UNAVAILABLE	C10S4, 78S J43, AJ66
14mm 1/2" Reach:	RHL27SA* RHL28SA* REL37B NON-SHIELDED UNAVAILABLE EL602YC	HL26P/HL601P* HL31P/HL602P* REL37W, REL38B L34R, AJ10 EL601Y
14mm 3/4" Reach:	REN30S	

NOTES

Over Pressurized Lube Oil Filters

Have you ever had a filter that appears to be “BLOWN UP”? Looks like a balloon or the gasket is protruding from the base of the filter? Often the deformed filter is the only sign that a problem existed in the lube oil system.

The first thing you want to blame is the filter. However, if the pressure was sufficient to blow out the gasket or unroll the lockseam, the pilot may have experienced immediate and costly problems. This should be considered a non- airworthy condition.

A look at how a lube oil system functions will show that the oil pump creates oil pressure. A pressure-regulating valve controls the upper limit of this pressure, which is usually an integral part of the pump.

Figure 1 is a simplified diagram of the lube oil system showing the pump, regulating valve, filter and bearings.

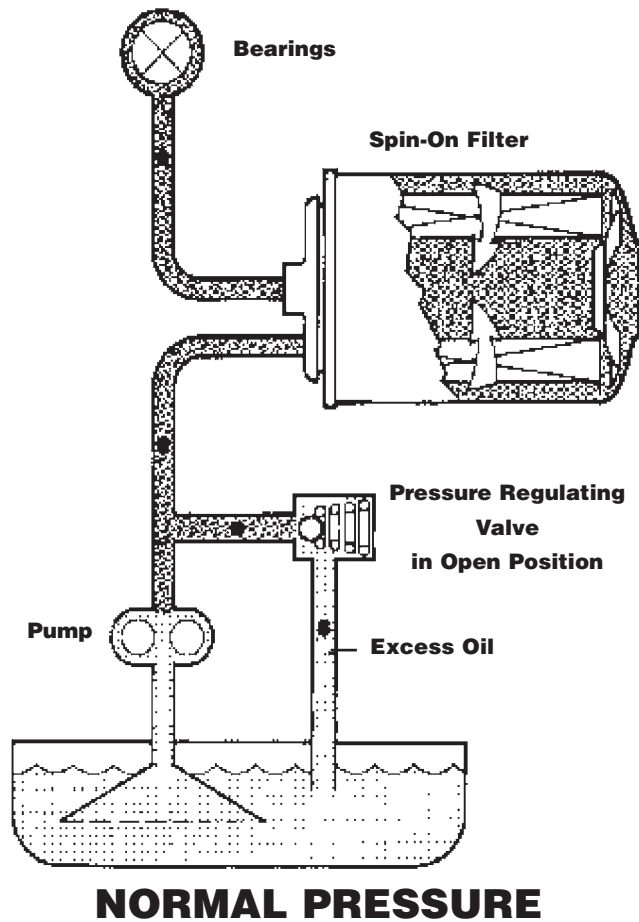

FIG. 1

The oil pump supplies sufficient flow to lubricate the bearings and other moving parts of the engine. This oil must be under pressure if it is to properly separate the highly loaded parts of an engine and prevent excessive wear. The purpose of the regulating valve is to provide a constant pressure for the system.

Continue On next page...

The regulating valve consists of a ball or plunger, which regulates pressure with the aid of a spring. The spring is calibrated so that the plunger will lift off its seat when the oil pressure reaches the desired setting. Once the valve is open, the pressure remains fairly constant with only small changes occurring as the engine rpm varies.

The filter and all other components in the oil system are subjected to the pressure established by the regulating valve. If this pressure is excessive, filter damage may occur. This is the point that many mechanics that are not familiar with lube systems fail to realize. Just remember any blockage in the system can also send the pressure beyond what the filter can stand which is rated at 400 psi. Burst.

Figure 2 shows the system operating with the regulating valve stuck in the shut position. Under this condition the pressure will build up in seconds and unless something happens to relieve the pressure the filter will become the victim and not the cause. With a high spike of pressure the gasket will blow out or the lockseam will unwind as the pressure increases.

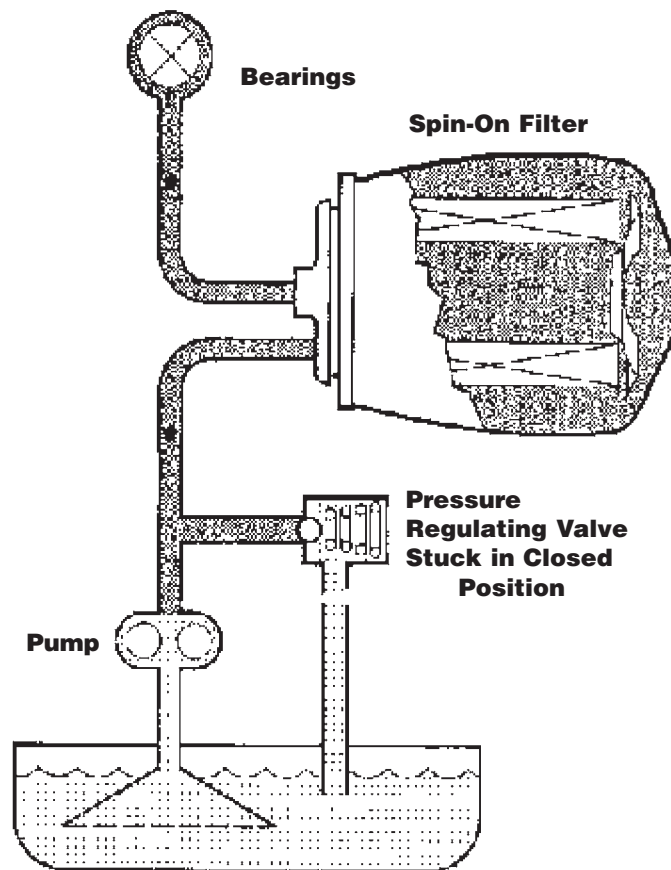

EXCESSIVE PRESSURE

FIG. 2

**In conclusion, if a filter distorts due to over pressure in the system, the fault might be the regulating valve
Not the filter**

CHAMPION AEROSPACE PRODUCTS WARRANTY

SPARK PLUGS, IGNITERS, OIL FILTERS, LEADS & EXCITERS

Champion Aerospace LLC ("Champion") warrants that spark plugs, harnesses, oil filter, exciters, leads and igniters sold by it are, at the time of delivery, free from defects in material and workmanship, provided that no warranty is made with respect to:

- (a) any product that has been subject to negligence, accident or improper storage;
- (b) any product that has been improperly installed or maintained; or
- (c) any product that has been operated beyond normal or recommended replacement intervals or wear limits.

Champion's obligation under this warranty is limited to the replacement of, or at Champion's option, the return of the purchase price of any product which is returned to Champion or its designated representative (at customer's expense) within one (1) year from the date of purchase and which, upon inspection by Champion, is found by Champion to be defective in material or workmanship. Champion shall not be responsible for the cost of labor removing any defective product or installing any replacement product.

THE AFORESAID WARRANTY IS EXCLUSIVE AND IN LIEU OF ALL OTHER WARRANTIES, WHETHER EXPRESSED, IMPLIED OR STATUTORY, INCLUDING, BUT NOT BY WAY OF LIMITATION, ANY WARRANTY OF MERCHANTABILITY OR FITNESS FOR ANY PARTICULAR PURPOSE.

NOTE: All service tools and test equipment bearing the Champion logo are distributed by Ideal Aviation, Inc. under license from Champion Aerospace LLC and are subject to the terms of a separate warranty provided by Ideal Aviation, Inc. All claims in connection with such products should be referred to Ideal Aviation, Inc., 564 E. Juanita Ave., Mesa, AZ 85204.

Champion Aerospace LLC LIMITATION OF LIABILITY

If Champion Aerospace LLC ("Champion") breaches any of its obligations to Distributor in connection with the sale of any products to Distributor, whether the breach is one of the warranty or for any cause whatsoever, whether in contract or in tort including negligence, Champion may request the return of the products and tender to Distributor the purchase price theretofore paid by Distributor and, in such event, Champion shall have no further redelivery of the products. If Champion so requests the return of the products, Distributor shall redeliver the products to Champion in accordance with Champion's instructions at Champion's expense. THE REMEDIES PROVIDED HEREIN AND IN CHAMPION'S WARRANTY SHALL CONSTITUTE THE SOLE RECOURSE OF DISTRIBUTOR AGAINST CHAMPION FOR BREACH OF ANY OF CHAMPION'S OBLIGATIONS IN CONNECTION WITH THE SALE OF ANY PRODUCTS TO DISTRIBUTOR, WHETHER THE CLAIM IS MADE IN TORT OR IN CONTRACT, INCLUDING CLAIMS BASED ON WARRANTY, NEGLIGENCE, STRICT LIABILITY, DECEIT FRAUD, MISREPRESENTATION OR OTHERWISE.

IN NO EVENT SHALL CHAMPION BE LIABLE FOR SPECIAL, INDIRECT, INCIDENTAL OR CONSEQUENTIAL DAMAGES (REGARDLESS OF THE FORM OF ACTION, WHETHER IN CONTRACT OR IN TORT INCLUDING NEGLIGENCE) NOR LOST PROFITS, NOR SHALL CHAMPION'S LIABILITY FOR ANY CLAIMS OR DAMAGE ARISING OUT OF OR CONNECTED WITH THE MANUFACTURE, SALE, DELIVERY OR USE OF ANY PRODUCTS EXCEED THE PURCHASE PRICE OF THE PRODUCTS.

Warranty Terminology

The following serves as a basic explanation of some of the terms used in the Champion warranty. In no event does the following amend or expand Champion's warranty. Furthermore, paragraph 3 through 9 lists several examples which are in no way exclusive to any other scenario.

1. Defect in Material. Defect in the materials used in the product. Examples: a defect in the metal used in this product.
2. Defect in Workmanship. Defect in the workmanship involved in the direct manufacture of the product.
3. Negligence. Any type of mishandling or unreasonable handling of the product or handling of the product which results in damage.
4. Accident. An event beyond the reasonable control of the person involved.
5. Improper Storage. Storage in any environment or location which may cause damage. Example: storage of the product outside of the protective poly tubes.
6. Improperly Installed. Installation not in strict accordance with Champion's specifications. Example: the use of pliers instead of an approved wrench to tighten the product. Example: the installation of the product of an unapproved application.
7. Improperly Maintained. Maintenance not in strict accordance with Champion's specifications. Example: the failure to inspect or replace at the specified or proper time (hours or cycles).
8. Operated Beyond Normal or Recommended Replacement Intervals. Operation beyond normal replacement levels. Example: the continued operation of an igniter at 401 cycles if it requires, by use or specification, replacement at 400 cycles.
9. Operated Beyond Normal or Recommended Wear Limits. Operation beyond normal wear or recommended limits. Example: the continued operation of an igniter 8.34 mm if, by use or specification, it has a maximum ground electrode (shell) erosion limit of 8.33 mm (.328 in.).

Any igniter that has been subjected to:

Negligence	Improper Maintenance
Accident	Operated Beyond Replacement Interval
Improper Storage	Operated Beyond Wear Limits (collectively, the "Factors")
Improper Installation	

... is beyond warranty coverage. Champion is in no way responsible for ascertaining the presence of any of the above factors; instead, the party to whom Champion extends the warranty is responsible to insure that the above factors do not exist.

If an igniter is replaced during troubleshooting and Champion finds the igniter to be serviceable per the approved Component Maintenance Manual or Igniter Technical Notice and Champion notes no material or workmanship defect during the investigation, or notes or discovers the existence of one or more of the Factors, Champion will not allow warranty replacement or credit.

If Champion notes a material or workmanship defect at the warranty investigation and notes that no Factors exist, a replacement or credit will be issued in accordance with the Champion Aerospace LLC Warranty Statement.

For Technical Assistance Contact:

Champion Aerospace LLC
Product Support/Technical Services
1230 Old Norris Road Liberty, SC 29657
864-843-5400
Email: support@champaero.com



Champion Aerospace LLC

Committed to the Aviation Industry

Our investment in aviation extends far beyond the manufacture and sale of spark plugs, filters, leads, exciters, and igniters. We actively support the industry groups shown here through direct and associate memberships.



Aviation Distributors & Manufacturers Association



Professional Aviation Maintenance Association

Distributed by:

