

INSTRUCTION MANUAL

CA-1550 – CML

BATTERY CHARGER / ANALYZER



PLEASE NOTE: This Manual applies to Power Products Serial Numbers Q900 and higher,
and all Power Products by Lamar serial numbers.

Lamar Technologies LLC

14900 40th Ave NE

Marysville, WA 98271

Cage Code: 3RCD2

Ph: (360) 651-8869 • Fax: (360) 651-6677

E-mail: admin@lamartech.com

TABLE OF CONTENTS

1	SYSTEM OVERVIEW ...	1
	1.1 SYSTEM OVERVIEW.....	1
	1.2 DISPLAYS AND CONTROLS.....	2
2	INSTALLATION.....	3
	2.1 LINE VOLTAGE	3
	2.2 TERMINALS ...	4
	2.3 SPACE REQUIREMENTS.....	4
3	OPERATING GUIDE - CHARGING ...	5
	3.1 CHARGE CHARACTERISTICS	5
	3.2 CHARGING METHODS	6
	3.3 PREPARATION FOR CHARGING	7
	3.4 CHARGE TIME	9
	3.5 SETTING CHARGE VOLTAGE AND CURRENT.....	9
4	OPERATING GUIDE - DISCHARGING	13
	4.1 DISCHARGE CHARACTERISTICS	13
	4.2 DISCHARGE CAPACITY TESTING ...	15
	4.3 PREPARATION FOR TESTING ...	16
	4.4 DISCHARGE TIME	18
	4.5 CUTOFF VOLTAGE	18
	4.6 SETTING DISCHARGE CURRENT	21
	4.7 TEST COMPLETION AND ANALYSIS.....	22
5	CALIBRATION AND MAINTENANCE ...	24
	5.1 OVERVIEW OF CALIBRATION	24
	5.2 VOLTMETER CALIBRATION	24
	5.3 AMMETER CALIBRATION	28
	5.4 SHUNT VERIFICATION	31
	5.5 DISCHARGE CURRENT OPERATING RANGE	32
	5.6 MAINTENANCE.....	32
6	TROUBLE-SHOOTING	34
7	SPECIFICATIONS	36
	WARRANTY	37
	CERTIFICATION OF CALIBRATION.....	38

1 SYSTEM OVERVIEW

1.1 SYSTEM OVERVIEW

The CA-1550 Charger/Analyzer is a self-contained unit for charging and discharge capacity testing of rechargeable batteries. It has been designed to accurately test, charge and guarantee the emergency capacity of sealed or vented lead-acid or nickel-cadmium batteries. Guaranteed emergency capacity is especially important for aircraft batteries.

The unit comes in a convenient protective carrying case. It is very easy to move around to accommodate flexibility in the work environment, whether used portable or in the hangar or battery shop. The flexibility of charge and discharge parameters of the CA-1550 makes it usable for a wide variety of batteries and voltages. The unit accurately charges and tests lead-acid batteries of 12 or 24 volts, as well as nickel-cadmium batteries of a single cell to 24 volts.

The charge unit of the CA-1550 allows charging at both constant potential and constant current to give maximum flexibility in selection of charge method. The charger has an adjustable charge current from 0 to 25 amperes, and an automatic timer for charge time selection.

The discharge unit of the CA-1550 enables battery capacity testing with a constant current of 0 to 50 amperes (usually set to 80-100% of the battery's capacity rating) for a preset time. The unit automatically analyzes the discharge characteristics and passes or fails the battery depending on the battery's ability to maintain the specified minimum voltage for the duration of the test.

1.2 DISPLAYS AND CONTROLS

The CA-1550 has been designed to have very simple and easy to understand controls and displays.

Two digital panel meters allow viewing of charge and discharge current and voltage. A digital electronic timer displays elapsed time and can be set to any fixed duration period. Light indicators display if the unit is in charge or discharge mode and also indicate battery pass or reject status after a discharge test (see Figure 1-1).

1. SYSTEM OVERVIEW

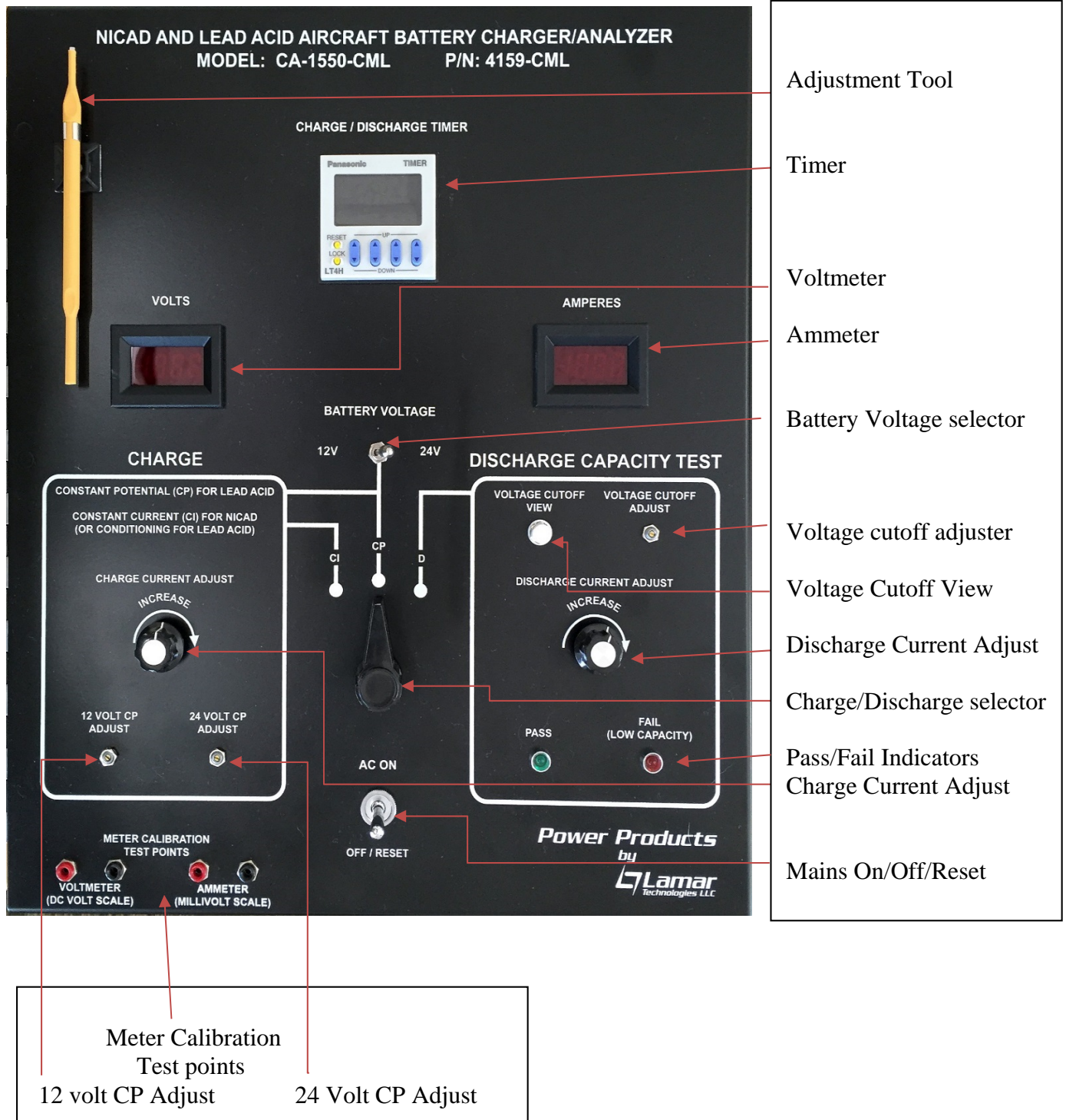

Figure 1-1. Controls and displays of CA-1550

2 INSTALLATION

2.1 LINE VOLTAGE

The CA-1550-CML can operate on either 115 or 230 volts AC. The desired line voltage can be changed by opening the unit and modifying the voltage-set jumper(s). The unit is factory-preset at 115 volts AC.

WARNING: Ensure that the unit is turned off and that no battery is connected before attempting to open the cover.

CAUTION: Ensure that the unit is set for the appropriate line voltage before operation.

- A. Turn off the unit and remove any battery
- B. Open the cover by first unscrewing the two screws on the far right of the front cover.
- C. Locate the four position terminal strip with jumper(s). Note: There is a red stripe on top of each jumper in the photo below.
- D. Two jumpers are used for 115VAC input and one jumper (across the middle two screws) is used for 230VAC input. See Figures below.

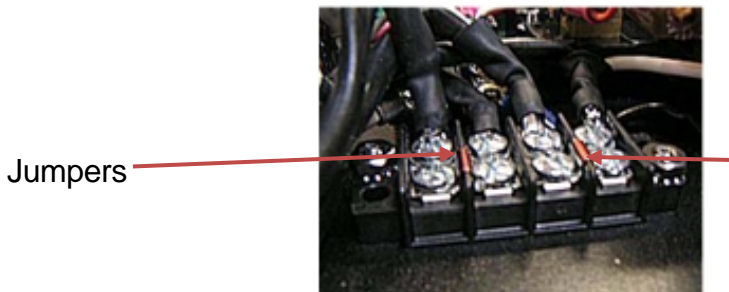

115 volt AC setting



230 volt AC setting

- E. For 230 VAC operation, the 115 VAC cord must be replaced with one for 230 VAC in required country configuration.

NOTE: If the plug has to be changed make sure to connect the green AC line wire to ground.

Connect the unit to a wall outlet with a 15-20 ampere capacity. Sharing of the line with other equipment may result in erratic operation if other equipment draws high pulse or surge currents.

NOTE: The CA-1550 will maintain its operational integrity with line fluctuation up to $\pm 10\%$.

2.2 TERMINALS

Two important points about the DC battery cable and connector are:

- A. If the aircraft battery quick disconnect connector is removed, the ring terminals can be used to connect to a post terminal battery.

WARNING: Correct polarity must be observed.

- B. If the cable is extended or repaired during maintenance, the sensing leads which run with the heavy DC cable must be connected to the new terminal (see section 5.6).

2.3 SPACE REQUIREMENTS

The CA-1550 system comes in a sturdy transit case. It occupies 17" x 20" (432 mm x 508 mm) of table top space and weighs about 55 pounds. Place the unit on a sturdy workbench in a well-ventilated area with the battery adjacent to it.

The top of the unit has air flow from hot resistors. Always leave the cover open and the resistor vent uncovered when in operation, to maintain proper air flow.

NOTE: In non air-conditioned rooms it is recommended that circulating or extracting fans be used to aid in the removal of heated air.

NOTE: Operation in dusty or otherwise dirty air environments will severely reduce the cooling capacity of the fans and can lead to premature failure.

3 OPERATING GUIDE - CHARGING

3.1 CHARGE CHARACTERISTICS

The constant current charge characteristics of a lead-acid cell with respect to cell voltage, ampere-hours input, specific gravity and rate of gassing at constant current can be seen in Figure 3-1.

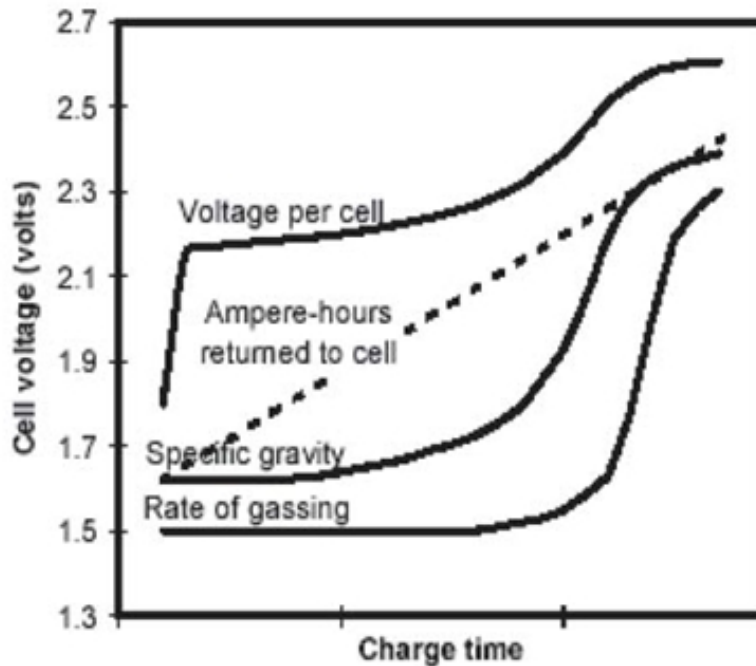

Figure 3-1. Charge characteristics of a lead-acid cell

As shown by the curve in Figure 3-1 the cell voltage of a discharged battery rises rapidly when the battery is first placed on charge. The extent of the initial rise depends on the charging rate. As the charge continues, the voltage rises at a slower rate and eventually levels off when a full state-of-charge is reached. It can be seen that the specific gravity reading lags behind the rate of ampere-hour return during most of the charging cycle. Consequently, the specific gravity is not indicative of the available ampere-hour capacity until the cell approaches a full-charge state.

When a battery reaches a full state-of-charge the voltage of the battery will stabilize and remain constant or decrease. The charging should discontinue at this stage. A minimum of 100% of previous discharged ampere-hours are required.

In general a vented battery may be charged at any rate that will not produce excessive gassing or electrolyte temperatures above 115°F (46°C). Sealed lead-

acid batteries should never be charged in a constant-current mode with a current greater than $C / 10$ (C equals the rated ampere-hour capacity of the battery). During constant current charging at a rate in excess of $C / 10$, oxygen is produced at an excessive rate. The resulting increasing pressure will cause the cell to vent. Venting of gasses results in a depletion of electrolyte. As the electrolyte cannot be replaced in a sealed battery, the cell will dry out resulting in a decrease in capacity and eventually battery failure. Therefore constant-potential charging is the recommended charge method for sealed batteries (SLAB).

3.2 CHARGING METHODS

There are two main methods of charging a battery: 1) constant current; and 2) constant potential. In what follows both methods will be described in some detail.

3.2.1 CONSTANT-CURRENT CHARGE METHOD (CI)

In this method the current remains at a preset level while the voltage can reach a high level, e.g. 34-37 volts.

An advantage of the constant-current charge method is that the ampere-hour input into the battery can be determined precisely by multiplying the charging current with the charge time in hours. However, it is necessary to ensure that the battery is not charged at a high rate for an excessive period of time. Such overcharging can result in overheating, excessive gassing, and possible damage to the battery.

3.2.2 CONSTANT-POTENTIAL CHARGE METHOD (CP)

A charge source applies a fixed (constant) voltage (potential) to the battery. The current supplied by the charge source fluctuates (rises and falls) with the battery voltage.

There are several advantages of the constant-potential charge method. First, there is less danger of gassing at an excessive rate. Secondly, batteries of the same nominal voltage but with different capacities can be connected in parallel directly to the charging source. Thirdly, batteries are charged more rapidly and with less attention.

3.2.3 LEAD-ACID BATTERIES

With the constant-current charge method the voltage can climb to 34-37 volts. Therefore, this method should normally not be used to charge lead-acid batteries, especially not the sealed type (SLAB). It is preferred to charge a sealed lead-acid battery in constant-potential mode at a voltage of 28.6 ± 0.2 volts for four hours or until the charge current drops below one ampere.

The constant-current charge method can however be used for reconditioning SLABs. The current must be set low and the timer set to 12-18 hours. The battery should be periodically monitored for overheat during reconditioning. When the battery begins to accept charge current, it can be switched to constant-potential charging set to 14.5 (12 volt battery) or 28.6 volts (24 volt battery).

3.2.4 NICKEL-CADMIUM BATTERIES

Nickel-cadmium batteries may be initially charged with constant potential set to 14.5 (12 volt battery) or 28.6 (24 volt battery). After the initial charge the batteries can be topped with a low constant-current (usually C/10 charge to 1.55 volts per cell.

The nickel-cadmium can also be completely charged in the constant-current mode. The current would be adjusted to a lower rate for topping. A low constant current applied during a long time can also be used to eliminate fading, previously called the "memory effect", from nickel-cadmium batteries.

Refer to your manufacturer's maintenance manual for the recommended discharge times.

3.3 PREPARATION FOR CHARGING

Before charging the battery, read the component maintenance manual (CMM) or the operating and maintenance manual (OMM) for the specific battery. Ensure that the charge time and current or voltage from the battery manufacturer are followed.

It is recommended that a visual inspection of the battery is carried out in conjunction with testing and charging batteries. The charging, unless otherwise specified in the manufacturer's CMM/OMM, shall be conducted at room ambient temperature of 70°F to 85°F (21°C to 29°C).

1.1.1 VERIFY END VOLTAGE

The end voltage (in all charge modes) can be verified by the following steps: 1) turn unit power off; 2) disconnect any battery; 3) turn charge current to max; 4) turn unit power on; and 5) verify the end voltages on the CA-1550 digital voltmeter (see also Modify Constant Potential in section 3.5).

WARNING: Always turn the AC power switch off before connecting or disconnecting a battery

NOTE: Once set, all settings are maintained and need not be reset for duplicate charging

A. SWITCH OFF MAINS POWER

Turn off the AC on-off/reset power switch.



B. TURN DOWN CHARGE CURRENT

Repeatedly turn the Ampere Adjust knob fully counter-clockwise to set charge current to zero.

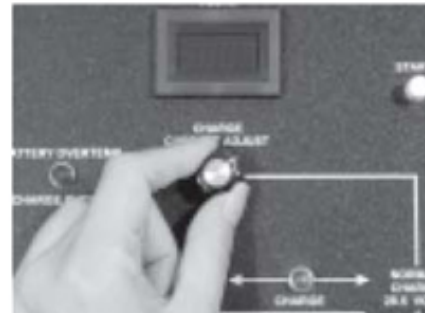

3.4 CHARGE TIME

3.4.1 TIMER UNIT SETTING

The CA-1550 has a built in timer, allowing charge time settings from 0.1-999.9 minutes.

3.4.2 CHARGE TIME SETTING

The charge time will be set based on the state of charge of the battery and at which rate the battery is being charged.

C. SET TIMER

Set the timer by pushing the up/down buttons to the required charge time.



D. SELECT CHARGE MODE

Turn the Mode Select knob to the desired charge mode: 1) Constant potential, CP; or 2) Constant current, CI.

NOTE: The factory-presets are 14.5 and 28.6 volts in constant-potential mode but can, if desired, be modified in step E.

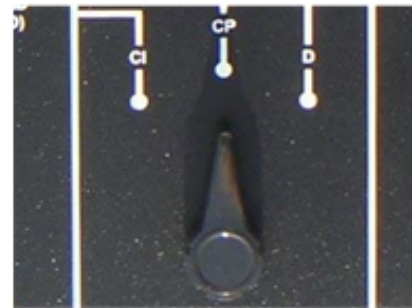

3.5 SETTING CHARGE VOLTAGE AND CURRENT

The CA-1550 provides maximum flexibility in setting charge parameters. Both the current and the voltage can be modified to accommodate different battery voltages and charge methods.

E. MODIFY CONSTANT POTENTIAL

If charging in constant-potential mode (CP), the constant charging voltage can be modified. This has to be done before connecting the battery.

1. Turn on the AC on-off/reset power switch.
2. Turn the Constant Potential Adjust Trimpot until the desired voltage is obtained. The voltmeter will display the voltage as it is being adjusted.
3. Turn off the AC on-off/reset power switch when voltage has been adjusted.

CAUTION: Ensure the unit is turned off before connecting the battery.



F. CONNECT BATTERY

Connect the battery DC cable to the battery. Ensure the connectors are plugged in completely.

NOTE: The factory-presets are 24.5 and 28.6 volts in constant-potential mode can, if desired, be modified in step E above.



G. SWITCH ON MAINS POWER

Turn on the AC on-off/reset power switch. The voltmeter reads the battery terminal voltage, the ammeter reads zero. The timer reads 0's and its red LED is off.



H. SET CHARGE CURRENT

1. CONSTANT-CURRENT CHARGING

Turn the Ampere Adjust knob until the desired charge current has been reached. The charge current is displayed on the ammeter as the current is being adjusted.

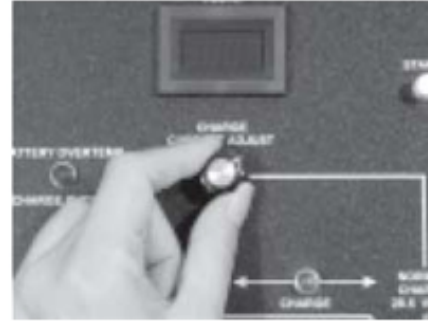

2. CONSTANT-POTENTIAL CHARGING

Turn the Ampere Adjust knob to max (fully clockwise) or to the desired current limit. The charge current is displayed on the ammeter as the current is being adjusted.

NOTE: The CA-1550 has a current limit of 25 amperes.

I. WAIT FOR CHARGE TO AUTOMATICALLY COMPLETE

During the charging of the battery the battery voltage, charge current, and elapsed charge time are displayed.

1. CONSTANT-CURRENT CHARGING

The current remains constant while the voltage increases during the time of charging.

2. CONSTANT-POTENTIAL CHARGING

The charger's end voltage remains constant while the current starts at a high value and gradually approaches zero as the battery approaches a full charge.

The actual charge voltage in both modes is determined by the battery, until the constant voltage is reached (28.6 volts in constant-potential or 35 volts in constant-current mode).

The test completes when the set charge time has been reached. The Off lamp illuminates.

For the constant-current method, if a second charging is desired (topping) repeat steps C, H, and I, with the current adjusted to a lower value (usually $C_1 / 10$)

K. SWITCH AC POWER OFF

Switch the AC on/off switch off before removing the battery.

NOTE: If in emergency it is required to stop charging, switch the unit to off. When charging is restarted the timer is reset to zero. It may be necessary to adjust the parameters (current and time) before resuming charge.

4 OPERATING GUIDE - DISCHARGING

4.1 DISCHARGE CHARACTERISTICS

The lead-acid and the nickel-cadmium cells are generally assigned nominal open circuit voltages of 2.10 volts and 1.35 volts respectively. Actual open circuit voltage at 75°F/ 25°C for a fully charged battery cell depends on state-of-charge and time after charge.

During discharge, the voltage of the cell or battery immediately begins to decrease because of the effective internal resistance of the cell. This includes the resistance of the terminal posts, active material, plate lugs and grids, separators, and contact resistance between the surface of the active material and the electrolyte. The internal resistance increases during discharge, being greater toward the end of discharge, when the terminal voltage is lower.

As voltage gradually becomes lower during discharge, the point of near exhaustion is reached. At this point, the discharge voltage curve begins to drop very sharply to a value which is of no further practical use. Usually this happens at 18-20 volts for a 24 volt lead-acid battery and 1 volt per cell for a nickel-cadmium battery (see Figure 4-1).

Battery manufacturers specify a cutoff voltage which the battery must exceed during a discharge test to have acceptable capacity. The cutoff voltage varies with the rate of discharge (the discharge current/time combination used to draw the same capacity). For example, the minimum cutoff voltages for a 30 ampere-hour, 24-volt naval aircraft lead-acid storage battery are generally specified as is shown in Table 4- 1.

Rate of Discharge	Discharge Current	Minimum Cutoff Voltage
5 hours	6 amperes	21.0 volts
2 hours	15 amperes	19.2 volts
1 hour	30 amperes	18.0 volts

Table 4- 1 Cutoff voltages at different discharge rates for a 30 ampere-hour, 24 volt lead-acid battery

The specified final minimum cutoff voltage represents the value of voltage at which the rated ampere-hour capacity of the battery must have been delivered for the specified discharge rate. Figure 4-1 is a typical discharge curve for a 40 ampere-hour sealed lead-acid (SLAB) aircraft storage battery discharged at a 1-hour rate of

40 amperes. From Figure 4-1, it is observed that at the end of 1 hour of discharge time, the battery voltage has reduced only to about 22 volts. Because the minimum required cutoff voltage is 18 volts at the 1-hour discharge rate, the battery exceeds the minimum requirements. With increasing hours of use or age, the battery capacity decreases. Therefore, battery manufacturers usually recommend testing for a capacity equal to 80% of the original ampere-hour rating.

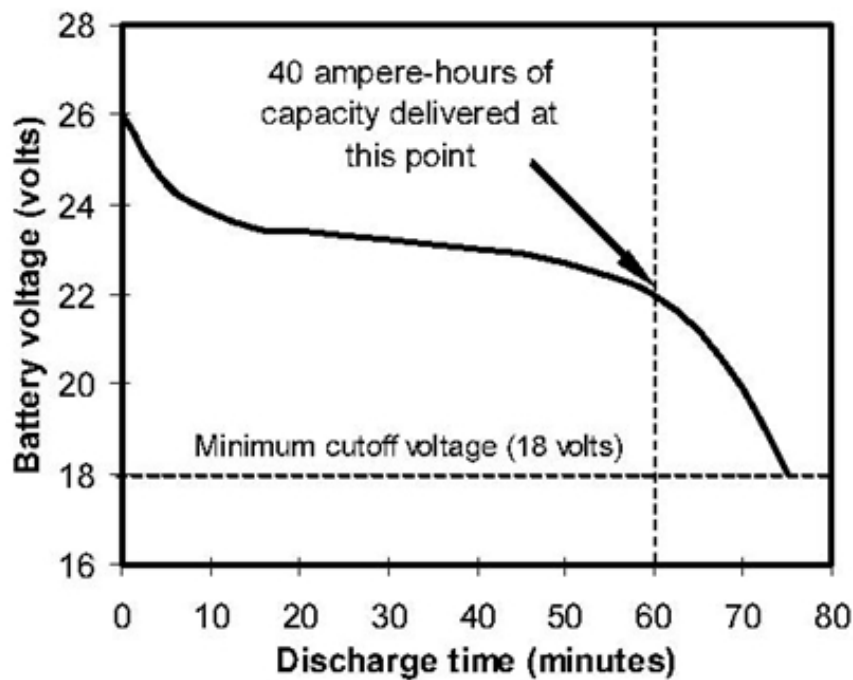

Figure 4-1. Typical discharge curve for 40 ampere-hour lead-acid aircraft battery

Figure 4-2 illustrates discharge curves for typical SLABs at different discharge rates. Note that the cell voltage drops much more rapidly at the higher discharge rates, i.e. the rates at which a greater current is drawn during a shorter period of time.

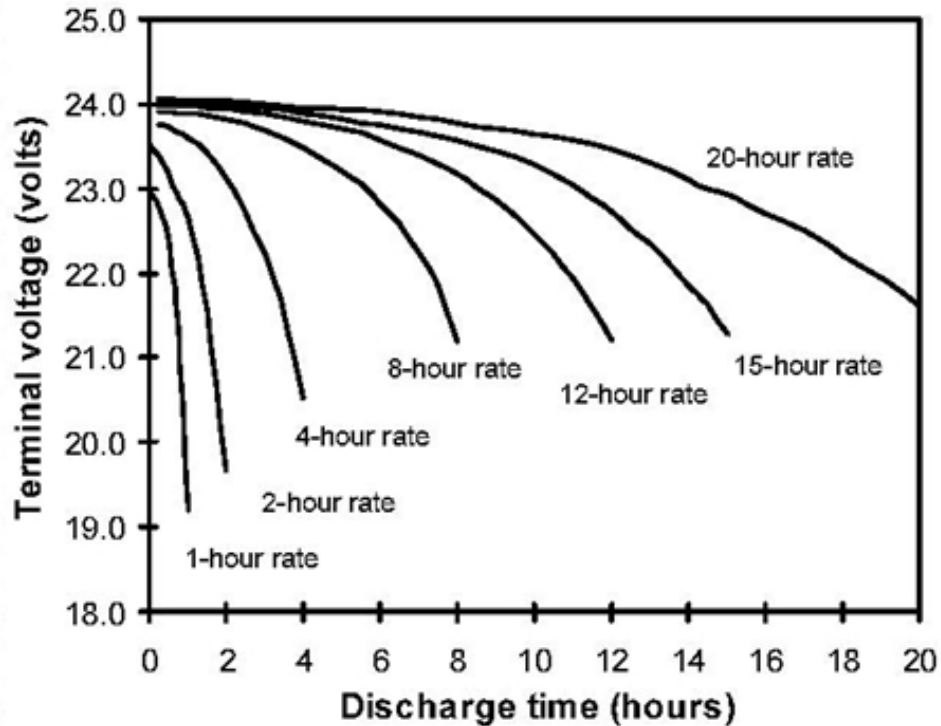

Figure 4-2. Typical discharge curves for SLABs at different rates

The discharge of a lead-acid battery beyond the point of which exhaustion of the cell is approached can be harmful, as the battery will form a sulfate deposit on its plates. This is particularly true if the battery is not soon recharged.

4.2 DISCHARGE CAPACITY TESTING

The purpose of a discharge test is to determine the long-term capacity of the battery. For a lead-acid aircraft battery, for example, the capacity test is the amount of current which can be delivered for one hour or until the voltage decreases to 1.5 volts per cell. This is considered the emergency capacity of the battery. The result of the test will determine whether to accept or reject the battery and which steps could be taken to electrically recondition the battery.

The amount of electrical capacity available from a fully charged nickel-cadmium or lead-acid battery is defined by the capacity rating of the battery and is stated in terms of ampere-hours. Because of internal resistance, the higher the discharge rate (higher current during a shorter period of time) demanded of a battery, the less usable capacity it can supply. See Figure 4-2.

4.2.1 Constant-Current Discharge Method

The most accurate and repeatable method of measuring capacity is to discharge the battery at a constant-current rate. This is also the method used by the CA1550. The load resistance in this method is continuously and automatically varied to maintain a constant discharge current as the battery's voltage decreases. A schematic of the circuit diagram for the CA-1550 can be seen in Figure 4-3. At the end of discharge, the calculation of ampere-hour capacity is the product of discharge current and the elapsed discharge time.

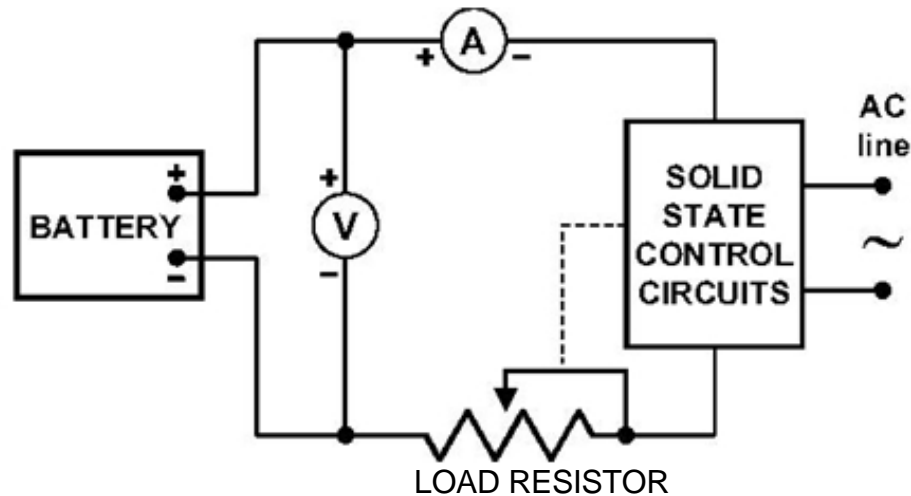

Figure 4-3. Circuit diagram for constant current discharge test

NOTE: Always read the battery manufacturer's operating instructions. Some lead-acid batteries are recommended at a 20 volt cutoff when tested for an hour at 80% of rated capacity. Some nickel-cadmium battery requirements are testing for two hours at half the rated capacity, and a 1 volt per cell cutoff.

4.3 PREPARATION FOR TESTING

Before starting the discharge test, read the component maintenance manual (CMM) or the operating and maintenance manual (OMM) for the specific battery to be tested. Ensure that the discharge rate and cutoff voltage from the battery manufacturer are followed.

It is recommended that a visual inspection of the battery is carried out in conjunction with testing and charging batteries.

The battery must be fully charged before testing starts, except for special tests.

WARNING: Always turn off the AC power switch before connecting or disconnecting a battery.

NOTE: The test, unless otherwise specified in the manufacturer's CMM/OMM, shall be conducted at room ambient temperature of 70°F to 85°F (21°C to 29°C).

A. SWITCH OFF MAINS POWER

Turn off AC on-off/reset power switch.



B. SELECT DISCHARGE MODE

Turn the Mode Select knob to the "Discharge" setting.

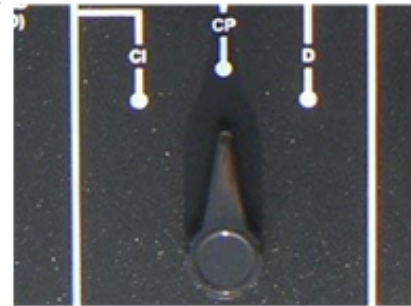

C. TURN DOWN DISCHARGE CURRENT

Turn the 3-turn Ampere Adjust knob fully counter-clockwise to set discharge current to zero. This prevents excess current, which may be too high for the battery, once the battery is connected and the discharge test has begun.



4.4 DISCHARGE TIME

4.4.1 TIMER UNIT SETTING

The CA-1550 has a built in timer, allowing discharge time settings from 1 to 999 minutes.

4.4.2 DISCHARGE TIME SETTING

The discharge time is usually set to 60 minutes, after which a pass/reject signal is given based on whether the battery reached the cutoff voltage or not.

To determine the full capacity of the battery a longer time can be set (several hours). The CA-1550 will then continue the discharge test until the cutoff voltage has been reached. The timer, cutoff voltage and discharge current displays will freeze at this point. The capacity can be calculated as the product of the discharge current and the time passed until the voltage cutoff was reached.

Refer to your battery manufacturer's maintenance manual for the recommended discharge times.

D. SET TIMER

Set the timer by pushing the up/down buttons to the required discharge time (usually 60 minutes)

CAUTION. For lead-acid batteries the time and voltage cutoff should be set with caution. If discharge continues too far beyond the point of exhaustion it may be harmful to the battery, unless the battery is soon to be recharged.



4.5 CUTOFF VOLTAGE

The CA-1550 will automatically stop the discharge test when the cutoff voltage has been reached. The cutoff voltage is set so that if the battery voltage is higher than the cutoff voltage when the discharge time has expired, the battery has passed the capacity test.

4.5.1 LEAD-ACID BATTERIES

Always refer to your battery manufacturer's maintenance manual for the most accurate information. For a 24 volt sealed lead-acid battery the cutoff voltage is usually set at 18 or 20 volts when discharged one hour at a current equal to the 80% of the battery's C 1-rate. See Table 4- 2 for examples of discharge test settings for sealed lead-acid batteries.

1-hour rating		Discharge settings		
Volts	Ampere hours	Time (min)	Rate (amperes)	Cutoff (volts)
24	10	60	8	18/20
24	15	60	12	18/20
24	20	60	16	18/20
24	30	60	24	18/20
24	40	60	32	18/20
12	10	60	8	9/10
12	15	60	12	9/10
12	20	60	16	9/10
12	30	60	24	9/10
12	40	60	32	9/10

Table 4- 2. Discharge test setting for sealed lead-acid batteries

4.5.2 NICKEL-CADMIUM BATTERIES

For nickel-cadmium batteries the cutoff voltage should be 1 volt per cell, when discharge tested at a current of approximately 80% of the C 1 - rate. For a 24 volt/10 ampere-hour battery with 19 cells, the cutoff voltage would be set to 19 volts when discharging at 8 amperes (see Table 4- 3).

1-hour rating		Discharge settings		
Volts	Ampere hours	Time (min)	Rate (amperes)	Cutoff (volts)
24	10	60	8	19
24	15	60	12	19
24	20	60	16	19
24	30	60	24	19
24	40	60	32	19
12	10	60	8	10
12	15	60	12	10
12	20	60	16	10
12	30	60	24	10
12	40	60	32	10

Table 4- 3. Discharge test setting for nickel-cadmium batteries

4.5.3 SETTING CUTOFF VOLTAGE ON THE CA-1550

E. Before setting the cutoff voltage, the unit must be turned on.



F. SWITCH ON MAINS POWER

Turn on the AC on-off/reset power switch. An audible alarm sounds, and the Accept lamp illuminates. Meters read all 6's or 8's. The timer reads 0's and its red LED is off. The Discharge Mode Lamp indicator is illuminated.



G. VIEW AND SET CUTOFF VOLTAGE

- Press and hold the Voltage Cutoff View button. The set cutoff voltage is shown on the voltmeter display.
- Use a 1/16 inch (2 mm) slot blade precision type screw driver set the Voltage Cutoff Adjust to the desired level.



NOTE: Actual cutoff voltages are slightly lower than the set nominal voltage in order to give the battery an "accept advantage" and allow the operator to observe a marginal battery and decide its acceptance or rejection. The actual cutoff value also depends on how fast the battery voltage is changing. Of course, the higher the voltage at acceptance, the better the battery.

4.6 SETTING DISCHARGE CURRENT

The discharge current in amperes is normally set equal to, or 80% of, the battery nominal 1-hour capacity rating (please refer to the battery manufacturer's maintenance manual). For example, a SLAB battery with a 30 ampere-hour 1-hour capacity rating would be tested with the discharge current set to 24 amperes.

Refer to your battery manufacturer's maintenance manual for the recommended discharge times.

Before setting the discharge current the CA-1550 must have been connected to the battery (see section 4.5) and the AC power switch must have been turned on.

H. SET DISCHARGE CURRENT

Slowly turn the multi-turn Ampere Adjust knob clockwise to the desired discharge current. The ammeter displays the current as it is being adjusted.

NOTE: The current is preceded with a negative sign indicating that current is being drawn from the battery.



4.7 TEST COMPLETION AND ANALYSIS

The CA-1550 automatically completes the test with the set parameters. However, it may be required to measure the individual cell voltages for nickel-cadmium batteries during the test (see section 4.7.2).

I. WAIT FOR DISCHARGE TEST TO AUTOMATICALLY COMPLETE

During the test the battery voltage, discharge current, and elapsed discharge times are displayed. The voltage will continuously decrease while the current remains constant. The test completes when either the set discharge time or the low cutoff voltage has been reached. An audible alarm sounds and the displays freeze at their final values.

J. 1. IF TEST PASSED

The green Accept lamp illuminates. This indicates the discharge has continued through the duration of the set discharge time (the red LED on the timer is off) without the cutoff voltage being reached. The battery is usually fit for service, after complete recharge. See 4.7.1 and 4.7.2 for respective battery type.



2. IF TEST FAILED

The Reject lamp illuminates if the discharge has been discontinued because the cutoff voltage has been reached before the completion of the set discharge time. The red LED on the timer remains on, but the time is frozen at the elapsed time at which the test failed. The battery is in need of reconditioning or must be rejected for aircraft service. Refer to the battery manufacturer's maintenance manual on how to proceed.

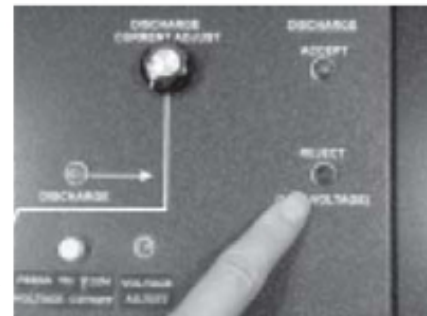

4.7.1 LEAD-ACID BATTERY

If the lead-acid battery has been accepted by the CA-1550 discharge test it has successfully completed the capacity test.

4.7.2 NICKEL-CADMIUM BATTERY

Check each cell with a digital voltmeter near the end of the test.

- A. If no cells have dropped below 1.0 volts at the end of the specified time the battery has successfully completed the capacity test.
- B. If any cells have dropped below 1.0 volt before or at the end of the capacity test the battery must be reconditioned (deep cycled). Please refer to the battery manufacturer's maintenance manual on how to proceed.

L. SWITCH AC POWER OFF.

Switch the AC on-off/reset switch off before removing the battery.

NOTE: If in emergency it is required to stop the test, switch the unit to off/reset. When the test is restarted the timer is reset to zero. It may be necessary to recharge the battery before resuming the test.



5 CALIBRATION AND MAINTENANCE

5.1 OVERVIEW OF CALIBRATION

The CA-1550 has been calibrated before shipment from the manufacturer. A certificate of calibration has been issued and is enclosed in the back of this manual. To ensure error-free operation over time the unit should be re-calibrated every 12 months depending on usage and changes in surrounding environment.

5.1.1 DIGITAL PANEL METERS

There are two main indicators that need be periodically calibrated: 1) the voltmeter; and 2) the ammeter (see Figure 1-1 in Section 1). The CA 1550 is equipped with two sets of test jacks for easy calibration of these digital display meters. In addition the internal shunt, even though calibrated and certified by the shunt manufacturer, can be verified.

5.1.2 TIMER

The timer is a very accurate crystal-controlled device (accurate to 1.0%), not prone to error. It cannot be re-calibrated, but unless an extremely accurate time reading is required, an accurate analog or digital stopwatch is adequate to validate its accuracy.

5.1.3 DISCHARGE CURRENT OPERATING RANGE

The CA-1550 discharge current operating range can be modified to be different than the factory-preset 50 amperes discharge current if necessary.

WARNING: Calibration should only be performed by trained personnel. If performed incorrectly it could result in electrical shock leading to injury or death.

5.2 VOLTMETER C

ALIBRATION

To calibrate the CA-1550 voltmeter, an external calibrated digital voltmeter is required. The unit does not require a battery for this calibration. The circuit diagram

for the calibration can be seen in Figure 5-1. The calibration steps are outlined below.

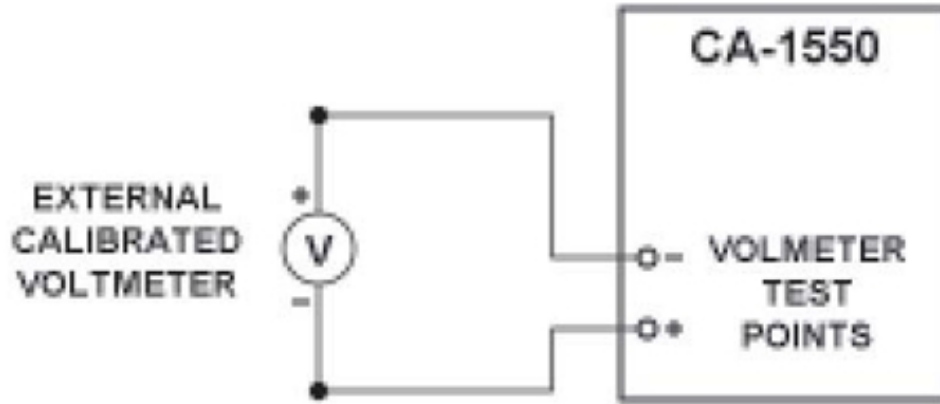

Figure 5-1. Circuit diagram for voltmeter calibration

A. SWITCH OFF MAINS POWER

Turn off the AC on-off/reset power switch.



B. SET LOW CHARGE CURRENT

Repeatedly turn the Ampere Adjust knob fully counter-clockwise to set zero. Turn the knob forward a few turns to enable the unit to provide voltage. No current will be drawn as no battery is connected.

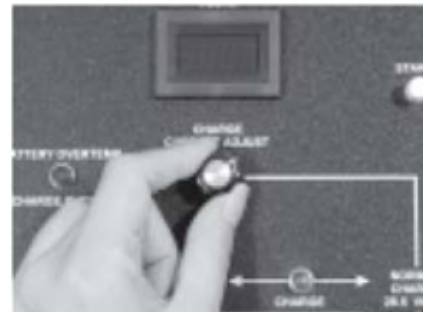

C. SET TIMER

Set the timer by pushing the up/down buttons to a time that will allow calibration to be completed before the time runs out (for example 60 minutes).



D. SET CONSTANT-POTENTIAL CHARGE MODE

Turn the Mode Select knob to Constant potential, CP.

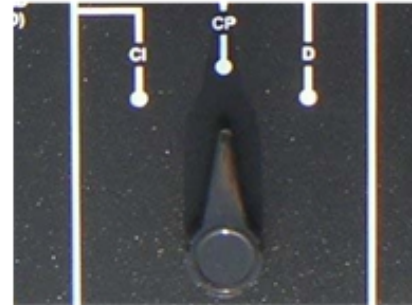

E. SWITCH ON MAINS POWER

Turn on the AC on-off/reset power switch. The voltmeter reads the set voltage, the ammeter reads zero. The timer reads 0's and its red LED is off. The Charge Mode Lamp indicator is illuminated.



F. CONNECT EXTERNAL VOLTMETER

Set the voltmeter to a DC voltage range appropriate for the set constant potential. Connect the external digital voltmeter into the voltmeter calibration points.



G. COMPARE VOLT READINGS

Compare the CA-1550 digital voltmeter reading with the external calibrated voltmeter.

- a. If readings differ less than ± 0.2 volts, the voltmeter is accurately calibrated. Turn AC power off.
- b. If readings differ more than ± 0.2 volts, continue with steps I through K.



H. OPEN THE CA-1550

If voltmeter differs more than ± 0.2 volts, open the front panel of the CA1550 by removing the two screws on the right side of the panel.

WARNING: Calibration needs to be performed with the unit's cover removed and mains power connected. It should only be performed by trained personnel. If performed incorrectly it could result in electrical shock leading to injury or death.

I. CALIBRATE VOLTMETER

The voltmeter can be found on the back side of the front panel. Locate the voltmeter trimpot.

Using a 1/16 inch (2 mm) slot blade precision type screw driver, adjust the embedded trimpot located at the rear of the voltmeter. Adjust until voltmeter reading matches that of the calibrated voltmeter (at least within ± 0.2 volts).



J. REPEAT FOR ADDITIONAL VOLTAGES

To verify the accuracy over the range of the meter, additional voltages can be checked. Since the CA-1550 digital meters are linear, checking two or three voltages are adequate to verify the range. The easiest way to check an additional voltage is to repeat step H but adjusting the Constant Potential Adjust Trimpot to another voltage (see section 3.5 on how to Modify Constant Potential).

5.3 AMMETER CALIBRATION

To calibrate the CA-1550 ammeter, an external calibrated digital voltmeter, set to the millivolt range, is required as well as a discharged battery. The millivoltmeter will read the millivolts dropped across the CA-1550 internal shunt when a charge current is applied. The circuit diagram for the calibration can be seen in Figure 5-2. The calibration steps are outlined below.

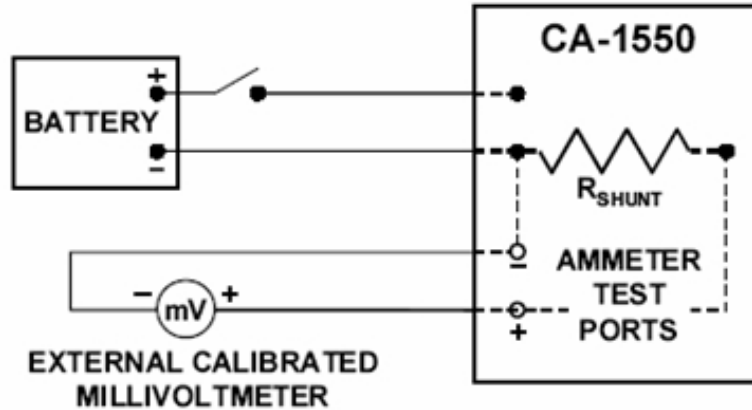

EXTERNAL CALIBRATED MILLIVOLTMETER

Figure 5-2. Circuit diagram for ammeter calibration

A. SWITCH OFF MAINS POWER

Turn off the AC on-off/reset power switch.



B. TURN DOWN CHARGE CURRENT

Turn the 3-turn Ampere Adjust knob fully counter-clockwise to set charge current to zero.



C. SET TIMER

Set the timer by pushing the up/down buttons to a time that will allow calibration to be completed before the time runs out (for example 60 minutes).



D. SET CONSTANT-CURRENT CHARGE MODE

Turn the Mode Select knob to Constant Current, CI.

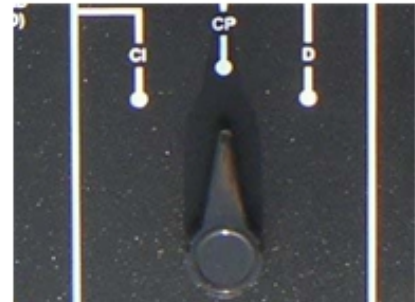

E. CONNECT BATTERY

Connect the battery DC cable to the discharged battery. Ensure the connectors are plugged in completely.



F. SWITCH ON MAINS POWER

Turn on the AC on-off/reset power switch. The voltmeter reads battery terminal voltage, the ammeter reads zero. The timer reads 0000 and its red LED is off. The Charge Mode Lamp indicator is illuminated.



G. SET CHARGE CURRENT

Turn the Ampere Adjust knob until approximately 15 amperes has been reached. The charge current is displayed on the ammeter as the current is being adjusted.

NOTE: If the battery is already significantly charged it may be hard to reach a 15 ampere current.

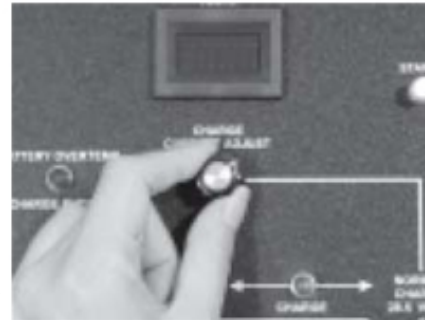

H. CONNECT EXTERNAL VOLTMETER

Set the voltmeter to a DC millivolt range. Connect the external digital voltmeter into the ammeter calibration points.



I. COMPARE AMPERE READINGS

Compare the CA-1550 digital ammeter reading with the external calibrated millivoltmeter. The external meter reads the millivolt drop across a 50 ampere/50 millivolt shunt. Every millivolt read on the external millivoltmeter represents 1 ampere. The readings should be within ± 0.2 millivolts (amperes).



- a. If readings differ less than ± 0.2 millivolts (amperes), the ammeter is accurately calibrated. Turn AC power off and disconnect battery.

-
- b. If readings differ more than ± 0.2 millivolts (amperes), continue with steps K through M.

J. OPEN THE CA-1550

If voltmeter differs more than ± 0.2 millivolts (amperes), open the front panel of the CA-1550 by removing the two screws on the right side of the panel.

WARNING: Calibration needs to be performed with the unit's cover removed as well as both mains power and battery connected. It should only be performed by trained personnel. If performed incorrectly it could result in electrical shock leading to injury or death.

K. CALIBRATE AMMETER

The ammeter can be found on the back side of the front panel. Locate the ammeter trimpot.

Using a 1/16 inch (2 mm) slot blade precision type screw driver, adjust the embedded trimpot located at the rear of the voltmeter. Adjust until voltmeter reading matches that of the calibrated voltmeter (at least within ± 0.2 amperes or millivolts).



L. REPEAT FOR ADDITIONAL CURRENT SETTINGS

To verify the accuracy over the range of the meter, additional current settings can be checked. Since the CA-1550 digital meters are linear, checking two or three current settings are adequate to verify the range. The easiest way to check an additional setting is to repeat steps H and J but setting a lower charge current in step H.

5.4 SHUNT VERIFICATION

The CA-1550 internal shunt is calibrated and certified by the shunt manufacturer. The shunt is a linear resistive device consisting of a heavy brass base and heavy manganin (copper alloy) resistance. It is not possible to calibrate the shunt. However the shunt can be verified with the help of an external calibrated shunt and a millivoltmeter (see Figure 5-3).

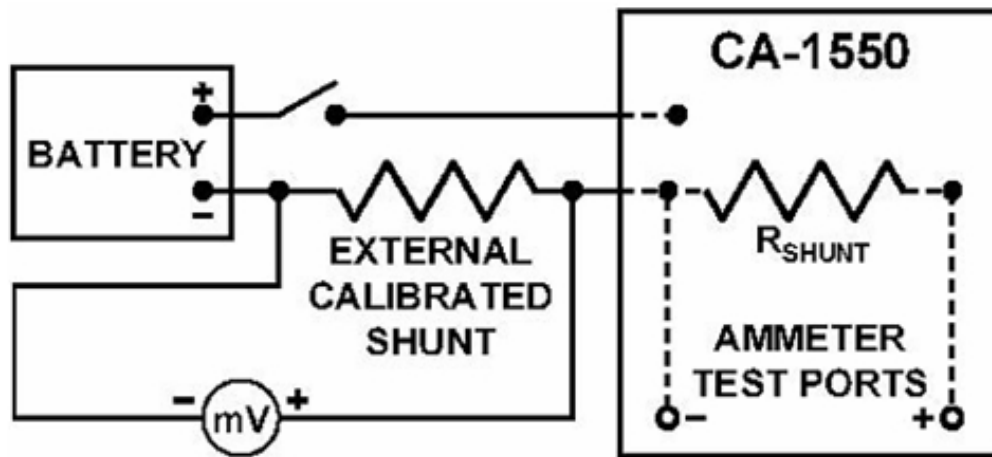

EXTERNAL CALIBRATED MILLIVOLTMETER

Figure 5-3. Circuit diagram for shunt verification

5.5 DISCHARGE CURRENT OPERATING RANGE

The CA-1550's factory preset max discharge rate of amperes can be increased past 50 amperes. If necessary to increase the discharge rate please contact the factory.

5.6 MAINTENANCE

Standard electrical equipment maintenance and cleaning procedures should be followed.

5.6.1 VENTS AND FAN

Regularly check that the fan vent next to the front panel is clean to ensure adequate cooling of the unit. This is especially important when the unit is placed in a dusty or otherwise dirty air environment.

5.6.2 DC BATTERY CABLE AND LEADS

Inspect DC battery cable and connector periodically. Replace damaged or worn cable.

WARNING: Disconnect AC voltage and battery before attempting to replace or secure cable.

The DC cable contains 4 leads. Two are heavy-gauge DC current leads for the battery discharge current. Two are light-gauge leads for sensing the battery voltage. Each current carrying lead has its sensing lead attached at the battery quick disconnect.

To replace DC battery cable proceed as follows:

- 1) Disconnect AC line and battery
- 2) Remove unit cover
- 3) Replace old cable from connector and unit
- 4) Make sure that each sensing lead is securely soldered or crimped to the termination of the DC cable at the connector and at the internal termination
- 5) Check all leads for tightness

5.6.3 REPLACEMENT OF FUSES

The CA-1550 is equipped with four fuses: (2) Two, 20 ampere AC line fuses; (1) one, 40 ampere DC charge line fuse; and (1) one, 70 ampere discharge line fuse. See specification in section 7 for the specific types of fuses required.

WARNING: Disconnect AC voltage and battery before attempting to replace any fuses.

To replace any of the fuses open the front panel of the CA-1550 by removing the two screws on the right side of the panel. Locate the two AC fuses on the front panel near the power cord entrance. Locate the DC charge fuse on the bottom of the unit near the terminal board. Locate the 70 ampere discharge fuse bolted onto the ammeter shunt on the bottom of the unit near the terminal board.

Remove the old fuse from the fuse holder and replace with the new fuse.

5.6.4 CLEANING AGENTS

Do not use acetone and other similar cleaning agents on the meters, timer or any plastic part.

6 TROUBLE-SHOOTING

<u>Problem</u>	<u>Possible Cause</u>	<u>Corrective Action</u>
A. Unit will not turn on	The AC power is not connected to unit	Check AC line with voltmeter
	Either AC line fuse is blown. May be due to incorrect AC line voltage setting.	Ensure correct AC line voltage setting. (see section 2.1) Replace AC line fuses located near the power cord entrance. (see section 5.6) Also see step G.
B. Unit turns on but will not start (timing)	Timer is set to zero time, or incorrectly to seconds or low decimal unit.	Increase the timer setting (see section 4.4)
C. Battery voltage reading erratic or not reading	Voltage sensing lead(s) at battery connector loose or broken	Replace or secure leads with both AC voltage and battery disconnected (see section 5.6)
D. Discharge test will not start	Battery is not sufficiently charged to start the test	Recharge battery before retrying discharge test
	Timer is set to zero time, or incorrectly to seconds or low decimal unit.	Increase the timer setting (see section 4.4)
	Cutoff voltage set higher than the actual battery voltage	Reset the cutoff voltage to a lower voltage (see section 4.6) or recharge battery.
	The lead-acid battery is sulfated and will not support a load	Recondition or reject the battery
E. Battery sufficiently charged but discharge test fails immediately as discharge current is increased	High resistance or open circuit in DC cable at aircraft connector, in the cable itself, or in the voltage sensing leads attached to connector	Inspect and measure resistance in DC cable and connector. If high or intermittent high resistance, the cable needs to be replaced
	The lead-acid battery is sulfated	Check all terminals. Set as low discharge current and look for arcing or heat generation.
	The nickel-cadmium battery inter-cell connectors are loose or contaminated causing high resistance	Check all terminals and inter-cell connectors. Set as low discharge current and look for arcing or heat generation.

<u>Problem</u>	<u>Possible Cause</u>	<u>Corrective Action</u>
F. Discharge current immediately surges to a high value and blows DC discharge fuses even though the current adjust knob is set low	Reversed polarity of battery connection	Ensure that polarity is respected on battery connection. If connector has been removed ensure that DC leads are not reversed.
	Defective discharge power control module	With AC voltage and battery disconnected, open unit and remove heavy leads from terminals on black 1"x1" (25mmx25mm) power module. Check resistance between terminals with ohmmeter. If short circuit, call Power Products technical support.
G. The DC charge fuse blown	Reversed polarity of battery connection	Ensure that polarity is respected on battery connection. If connector has been removed ensure that DC leads are not reversed.
	Defective charge power control module	With AC voltage and battery disconnected, open unit and remove ACL leads from terminals on black 1¾"x2¼" (45mmx60mm) power module (G1 and G2 tabs included). Check resistance between + and – terminals with ohmmeter. If short circuit, call Power Products technical service.

7 SPECIFICATIONS

<u>AC Line Input:</u>		115 volts \pm 10%, 50/60Hz, 14 amperes or 230 volts \pm 10%, 50/60 Hz, 7 amperes (selectable inside unit)
<u>DC Discharge Current:</u>	Capacity	0 - 50 amperes adjustable current
	Accuracy	\pm 2% from discharge initiation to cut-off
<u>Constant Current Charge Mode:</u>	Capacity	0 - 25 amperes adjustable, 35 volt limit
	Accuracy	\pm 2% from charge initiation to completion
<u>Constant Potential Charge Mode:</u>	Setting	Selectable 14.5/28.6 volts, 25 ampere limit
	Accuracy	\pm 2% from charge initiation to completion
<u>Timer:</u>	Setting	Adjustable from 0 to 999.9 units
	Units	Selectable on front of timer from 0.1 to 999.9
	Accuracy	\pm 1.0%
<u>Digital Meter Accuracy:</u>	Voltmeter	$< \pm$ 0.2 volts
	Ammeter	\pm 0.2 amperes
<u>Cooling:</u>		Fan cooled
<u>Housing:</u>		Compact transit case
<u>Outer Dimensions:</u>	Height	14 in. (356 mm)
	Depth	15 in. (381 mm)
	Width	10 ¼ in. (260 mm)
<u>AC Line Cord:</u>		AWG 14 3 wire grounded, IEC320 connector 6 ft long with 115 volt 15 ampere plug (supplied) User required to change to 230 volt IEC320 cord if needed
<u>DC Discharge Cable:</u>		4 ft Terminal w/Quick Disconnect Adaptor
<u>Weight:</u>		Net 53 lbs. (24.1 kg) Shipping 58 lbs. (26.3 kg)
<u>Fuses:</u>	AC line	20A/250V, type MDA 1 ¼ x ¼ (2)
	Charge line	40A/32V, type MDL 1 ¼ x ¼
	Discharge	70A/32V, type Littlefuse 0498070
<u>Adaptors Included:</u>		Alligator Clip Connector, 24V Aircraft Battery Connector, and Ring Terminal Connector

WARRANTY

1 YEAR WARRANTY

LAMAR TECHNOLOGIES LLC (LAMAR) warrants its products to be free from defects in workmanship and material for a one year period from the date of shipment to the distributor, original equipment manufacturer (OEM), or original end user. If any product shall prove to be defective during the warranty period, LAMAR will repair or replace such part.

There are no warranties that extend beyond the description on the face hereof. This warranty is in lieu of all other warranties, express or implied. LAMAR excludes liability for incidental and consequential damages.

An action for breach of this warranty must be commenced within one year after the breach is or should have been discovered.

LAMAR specifically disclaims all other representations to the first user/ purchaser, and all other obligations or liabilities. No person is authorized to give any other warranties or to assume any liabilities on LAMAR behalf.

CERTIFICATION OF FACTORY VERIFICATION

AIRCRAFT BATTERY CHARGER / DISCHARGE TESTER

MODEL: CA-1550-CML P/N: 4159-CML

MFD. BY: Lamar Technologies LLC

14900 40th Ave NE

Marysville, WA 98271

Cage Code #: 3RCD2

Tel: 360-651-8869 Fax: 360-651-6677

E-Mail: admin@lamartech.com

AC INPUT: 50/60 HZ 115 V 14A MAX., 230 V 7A MAX.

DC OUTPUT: CHARGE 0-25A

DISCHARGE: 0-50A MAX

Refer to Operating Instructions for more complete specifications. Standards Used Traceable to National Institute of Standards and Technology (NIST)

Calibrated Instruments:

a) Digital Multimeter _____

b) Digital Multimeter _____

c) Shunt _____

Auxiliary Non-Calibratable Equipment Used:

Batteries: _____

Lamar Technologies LLC Test Procedure LTS-1190

VERIFICATION:

AMMETER: WITHIN TOLERANCE _____

VOLTMETER: WITHIN TOLERANCE _____

SERIAL NO: _____ DATE OF MANUFACTURE: _____

VERIFIED BY: _____ DATE OF VERIFICATION: _____

Lamar Technologies LLC certifies that the above listed CA-1550-CML Battery Charger /Discharger meets or exceeds all published specifications. Accuracies of calibration of instruments used are traceable to the National Institute of Standards and Technology.

Power Products
by
The logo for Lamar Technologies LLC features a stylized blue lightning bolt symbol to the left of the company name. The word "Lamar" is in a large, bold, black sans-serif font, and "Technologies LLC" is in a smaller, black sans-serif font below it.

Lamar
Technologies LLC

*Designer and Manufacturer of Aircraft Lead-Acid and
Nickel-Cadmium Battery Support Equipment Since 1980.*

Lamar Technologies LLC
14900 40th Ave NE
Marysville, WA 98271
Cage Code: 3RCD2
Ph: (360) 651-8869 • Fax: (360) 651-6677
E-mail: admin@lamartech.com