

CAUTION
DO NOT ALLOW FIELD LEAD TO CONTACT AIRFRAME GROUND. CONTINUOUS LOSS OF ALTERNATOR FUNCTION WILL RESULT UNTIL THIS IS CORRECTED.

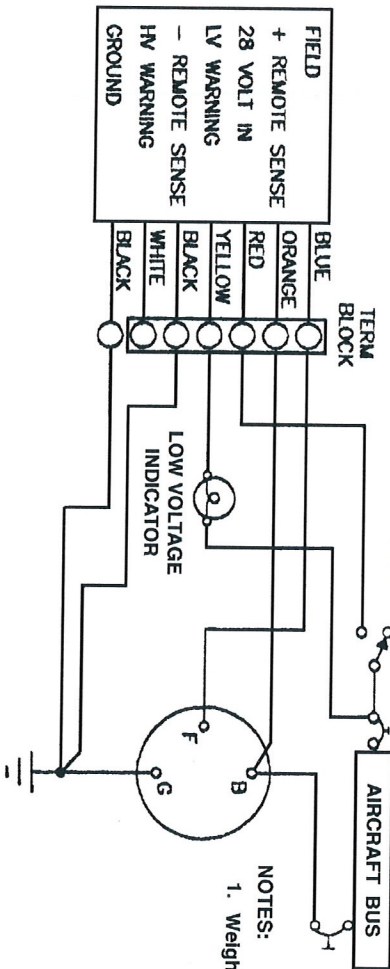

NOTES:
1. Weight is .5 pounds (.227 kg).

VR515G-2 (28 VOLT)

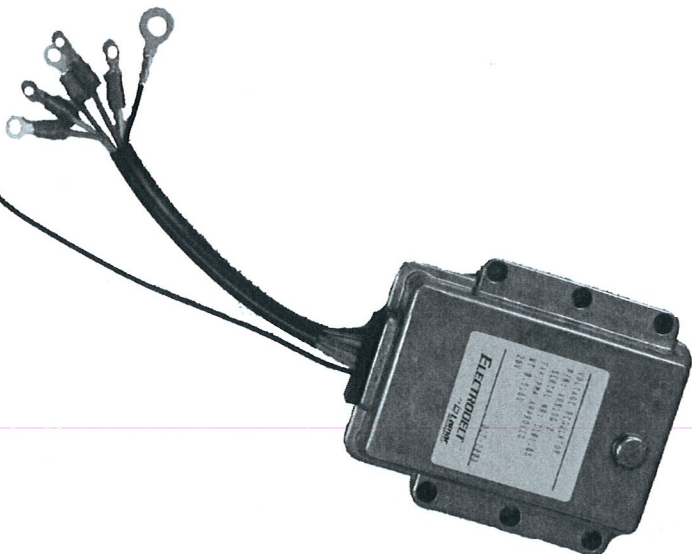

ORIGINAL

RECOMMENDED INTERFACE WIRING:

VR515G-2 VOLTAGE REGULATOR (28 VOLT)

Electrodelta™

by **Lamar Technologies LLC**

www.lamartech.com/electrodelta/

VR515G-2.A Data Sheet

Lamar Technologies LLC
14900 40th Ave. NE
Marysville, WA 98271
360-651-6666