

PLT-275AV

A

ALL DIAMETERS
MUST BE CONCENTRIC
WITH $\varnothing 0.010$ DIA

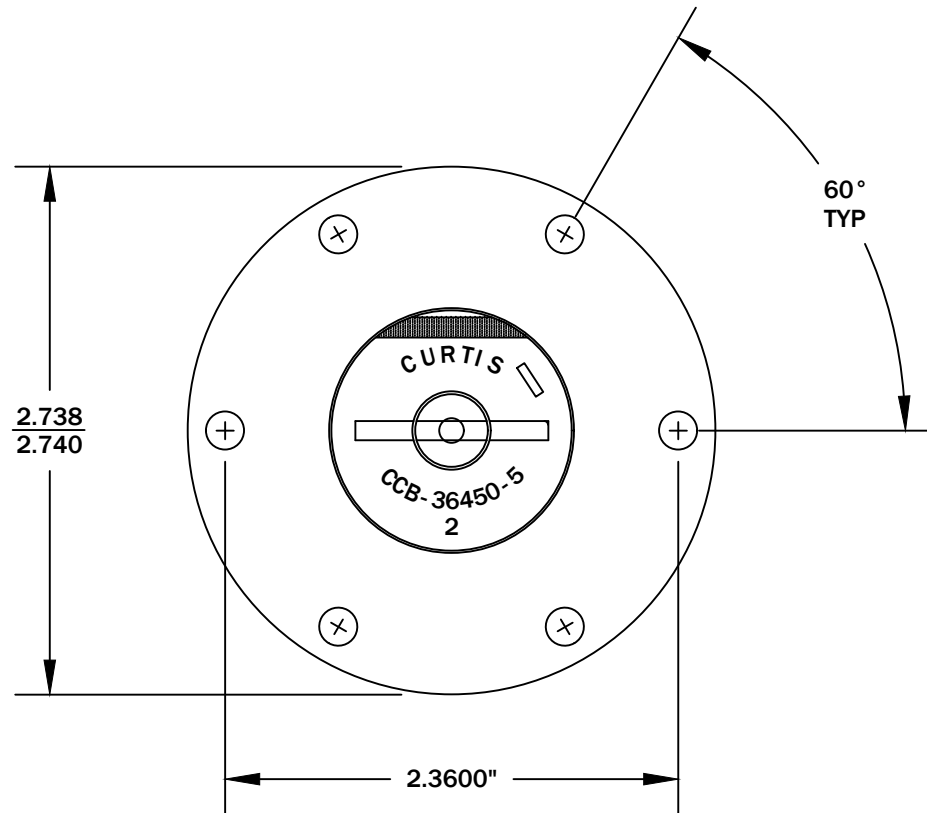

A	APPROVED ORIGINAL PRINT	05/25/15	G.H.	MATERIAL ALLUMINUM 6061-T6	FINISH 32	HEAT TREAT	DRAWN BY C.R.M.	ENG. G.H.	PROD. OK G.H.	NO. REQ.	SCALE 1X	
							5/25/15	5/25/15	5/25/15			
				NAME FLUSH VALVE FUEL PLATE						PIECE PART PLT-275AV		
				DATE CURTIS SUPERIOR VALVE CO., INC. CHANDLER, AZ						DATE 05/25/2015		
LET	REVISIONS	DATE	CHK									