

NOTES: UNLESS OTHERWISE SPECIFIED

1. MANUFACTURED AND INSPECTED IAW AS9100 QUALITY SYSTEM REQUIREMENTS.
2. ABBREVIATION USED IN TITLE IS: VALVE REGULATED SEALED LEAD ACID (VRSLA).
3. SEE DRAWING NO. CB-00411 AND PROCEDURE P-1000 FOR ASSEMBLY AND TEST INSTRUCTION. PROCEDURES AND ASSEMBLY DRAWINGS ARE FOR INTERNAL USE ONLY.
4. BATTERIES ARE RATED IAW INTERNATIONAL ELECTROTECHNICAL COMMISSION STANDARD 60952-1 AND RTCA STANDARD DO-293, UNLESS OTHERWISE NOTED.
5. DIMENSIONS ARE IN INCH [MILLIMETER].

REVISIONS			
REV	DESCRIPTION	DATE	APPROVED

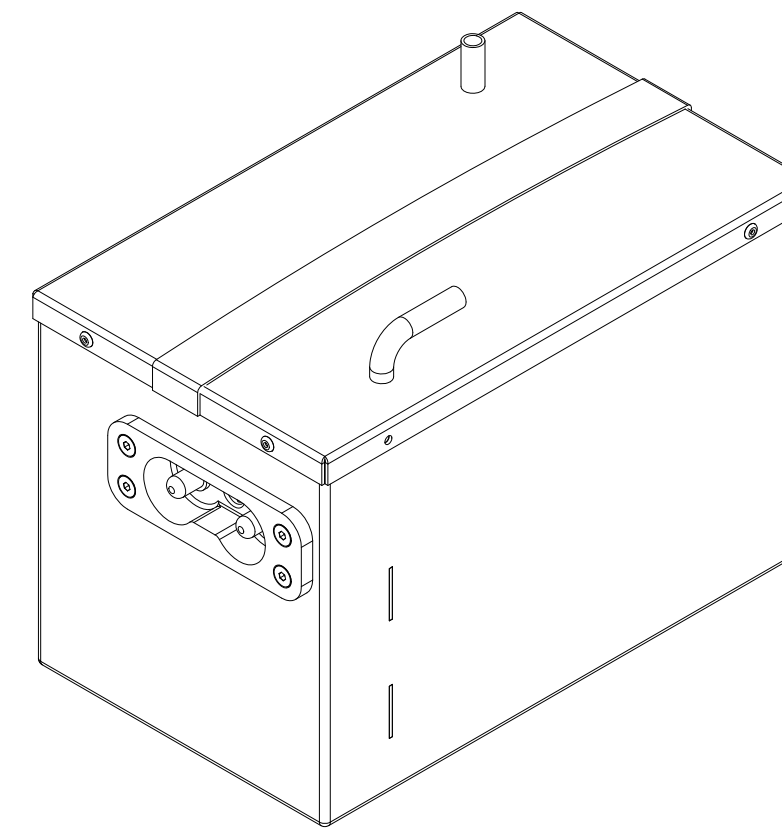
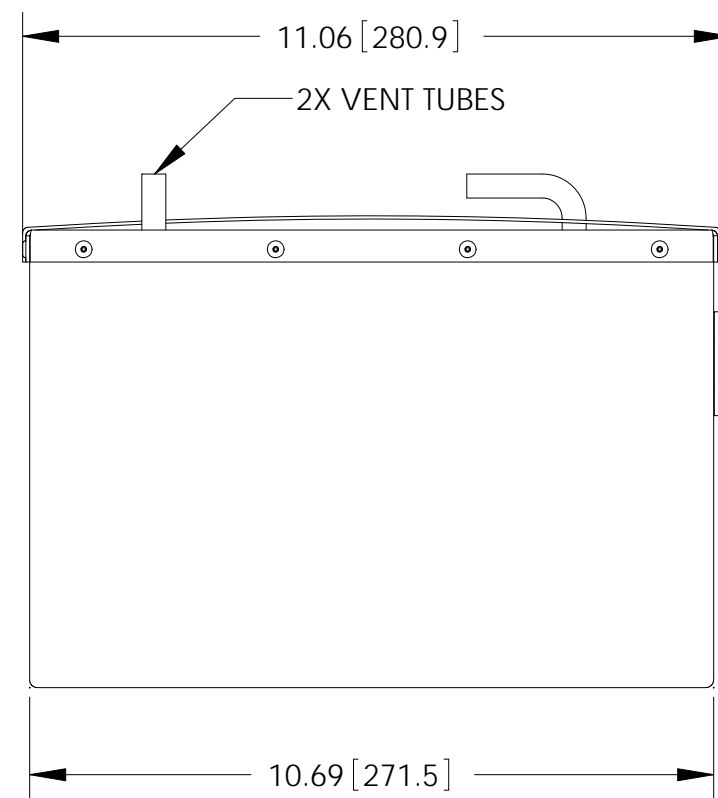
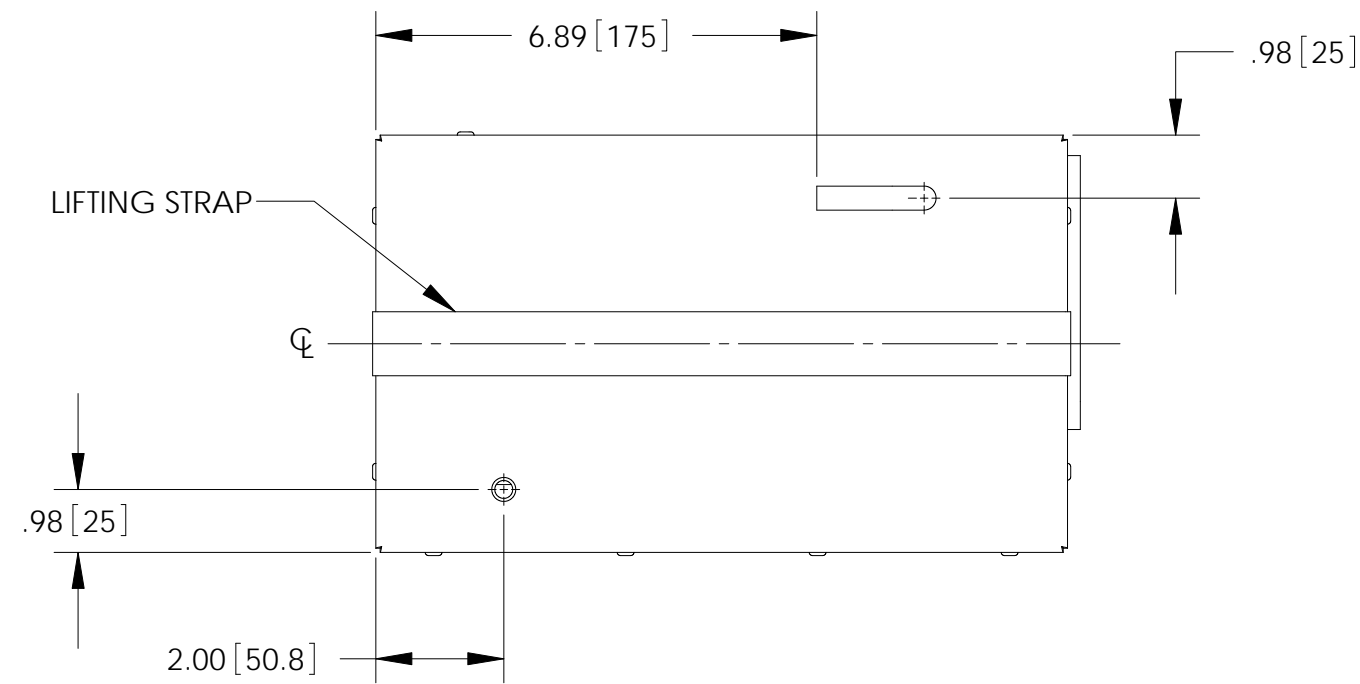

ISOMETRIC VIEW

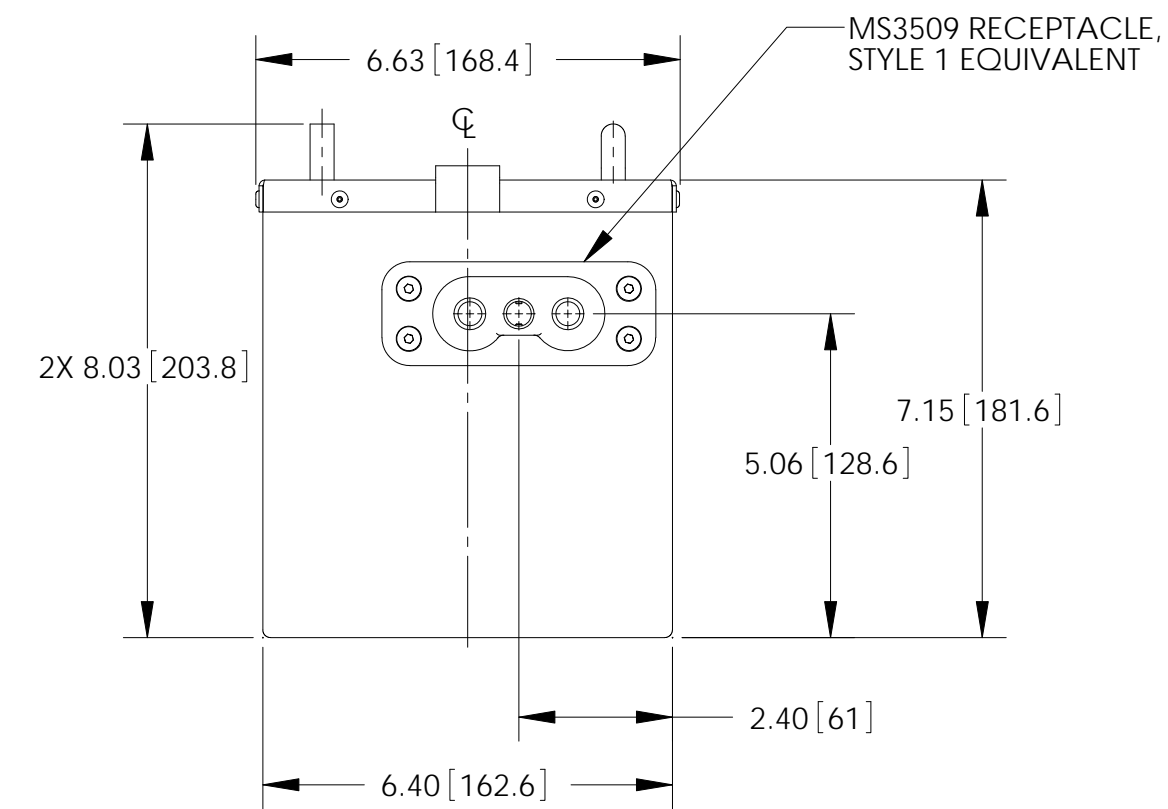

PART NUMBER	RG-42
MAXIMUM WEIGHT	43 LBS [19.5 KG]
RATED CAPACITY, C1	17 AH
POWER RATING AT 23 °C	Ipp 900 A, Ipr 625 A
POWER RATING AT -18 °C	Ipp 600 A, Ipr 425 A
POWER RATING AT -30 °C	Ipp 450 A, Ipr 300 A

ENVELOPE DRAWING

UNLESS OTHERWISE SPECIFIED DIMENSIONS ARE IN INCHES TOLERANCES ARE:			CONTRACT NO.		CONCORDE BATTERY CORPORATION 2009 SAN BERNARDINO RD, W. COVINA, CA 91790			
FRACTIONS	DECIMALS	ANGLES	APPROVALS	DATE	TITLE			
±1/32	.XX ± .06 XXX ± .030	±1°	DRAWN D. AYALA	6/25/10	BATTERY, VRSLA, 24 VOLT			
TREATMENT	NONE	CHECKED AMIII	APPROVED JBT	7/1/10	SIZE C	CAGE CODE 63017	DWG NO. RG-42	REV
FINISH	NONE	ISSUED JJ	7/15/10	SCALE 1:3	SHEET 1 OF 1			